

STATE OF NEVADA
Department of Education



2010
SCHOOL BUS STANDARDS

NEVADA STATE BOARD OF EDUCATION

Nevada State Board of Career & Technical Education

2010 Members

Christopher Wallace, President
Cliff Ferry, Vice President
Dave Cook, Clerk
Jan Biggerstaff
Gloria Bonaventura
Willa Chaney
Charlotte Hill
Adriana Fralick
Anthony Ruggiero
Craig Wilkinson
Zhan Okuda-Lim, Student Representative

NEVADA DEPARTMENT OF EDUCATION

Keith Rheault, Superintendent of Public Instruction
Gloria Dopf, Deputy Superintendent, Instructional Research & Evaluative Services
Greg Weyland, Deputy Superintendent, Administrative & Fiscal Services
Donnell Barton, Director, Child Nutrition and School Health
Diana Hollander, Program Officer, Pupil Transportation

INTRODUCTION

The purpose of the Nevada School Bus Standards is to provide state transportation personnel with minimum school bus standards/specifications for all new buses purchased by a district, charter or private school in Nevada. The Nevada School Bus Standards are based on the 2010 National School Transportation Specifications and Procedures Manual which was revised during the National Congress on School Transportation (NCST) in Warrensburg, Missouri in May of 2010. National School Specifications are revised by the congress every five years. Many sections of the 2010 National School Transportation Specifications and Procedures Manual have been used in this document.

Minimum school bus standards are strictly regulated by the Federal Motor Vehicle Safety Standards (FMVSA), and all new buses manufactured must meet these standards. States can exceed these standards.

The Nevada School Bus Standards was approved by the Nevada State Board of Career & Technical Education during the December 9th & 10th, 2010 meeting.

All Nevada School transportation personnel are required to adhere to these standards when purchasing new school buses in Nevada. These minimum standards are utilized by the Nevada Highway Patrol when inspecting new school buses as required by NRS 392.400.

It is the intent of these specifications to accommodate new technologies and equipment that will better safely facilitate the transportation of students. When the new technology, piece of equipment, or component is desired to be applied to the school bus, and it meets the following criteria, it may be acceptable.

The new technology, equipment or component shall not compromise the effectiveness or integrity of any major safety system, unless it completely replaces the system. (Examples of safety systems include, but are not limited to, compartmentalization, the eight light warning systems, emergency exit opportunity, and the uncluttered yellow color scheme. It shall not diminish the safe environment of the interior of the bus.

TABLE OF CONTENTS

Introduction.....	2
School Bus Types.....	7
Terms and Acronyms	8
Bus Body and Chassis Standards	
Air Cleaner.....	10
Aisle	10
Axles	10
Back-Up Warning Alarm.....	10
Battery-See Electrical	10
Brakes, General.....	10
Brakes, Hydraulic	11
Brakes, Air	11
Bumper, Front.....	12
Bumper, Rear	12
Ceiling-See Insulation and Interior.....	13
Certification	13
Clutch.....	13
Color	13
Construction.....	14
Crossing Control Arm.....	14
Defrosters.....	15
Doors.....	16
Drive Shaft.....	16
Electrical System	17
Emergency Equipment.....	21
Emergency Exits	22
Exhaust System.....	23
Fenders, Front	24
Fire Suppression Systems	24
Floors	24
Frame	25
Fuel System.....	25
Governor	26
Handrails.....	26
Heating and Air Conditioning Systems	26
Hinges	30
Horn	31
Identification.....	31
Inside Height.....	32

Instruments and Instrument Panel.....	32
Insulation.....	33
Interior.....	33
Lamps and Signals.....	34
Metal Treatment.....	36
Mirrors.....	37
Mounting.....	37
Oil Filter.....	37
Openings.....	37
Overall Length.....	37
Overall Width.....	38
Passenger Load.....	38
Public Address System.....	38
Retarder System (Optional equipment).....	38
Retro-Reflective Material.....	38
Road Speed Control.....	39
Rub Rails.....	39
Seat and Restraining Barriers.....	40
Shock Absorbers.....	42
Side Skirts.....	42
Steering Gear.....	42
Steps.....	42
Step Treads.....	43
Stirrup Steps.....	43
Stop Signal Arm.....	44
Storage compartment.....	44
Sun Shield.....	44
Suspension Systems.....	44
Throttle.....	44
Tires and Rims.....	44
Towing Attachment Points.....	45
Traction Assisting Devices.....	45
Transmission.....	46
Trash Container and Holding Device.....	46
Turning Radius.....	47
Undercoating.....	47
Ventilation.....	47
Wheelhousing.....	48
Windows.....	48
Windshield Washers.....	48
Windshield Wipers.....	48

Specialty Equipped School Bus Specifications

Introduction.....	49
Definition.....	50

General Requirements.....	50
Aisles.....	50
Glazing.....	50
Identification.....	50
Passenger Capacity Rating.....	50
Power Lifts.....	51
Regular Service Entrance.....	53
Restraining Devices	53
Seating Arrangements.....	54
Securement and Restraint System for Wheelchair/Mobility Aid & Occupant	54
WTORS.....	54
Special Light	55
Special Service Entrance.....	55
Special Service Entrance Doors.....	56
Support Equipment and Accessories	57
Technology and Equipment, New.....	58

Alternative Fuels

Introduction.....	59
General Requirements.....	59

Appendix A

Definitions	62
-------------------	----

Appendix B

School Bus Chassis & Body & Reflective Material	82
National School Bus Yellow.....	82
Bus Body Heating System Test	82
Placement of Retro-reflective Markings and White Roof	88
Placement of Retro-reflective Markings.....	89
Noise Test Procedure	90
Retro-reflective Sheeting-Daytime Color Specifications	91
School Bus Seat Upholstery Fire Block Test.....	91
Camera View Area.....	92

SCHOOL BUS TYPES

TYPE A BUS



The TYPE A school bus is one of seven vehicle types that can be manufactured to federal motor vehicle safety standards for school buses. It consists of a body constructed upon a cutaway front-section vehicle with a left side driver's door, designed for carrying more than 10 persons. This definition includes two classifications: TYPE A-1, with a Gross Vehicle Rating (GVWR) of 10,000 pounds or less, and a TYPE A-2, with a GVWR of 10,000 pounds or more. TYPE A school buses meet all Federal Motor Vehicle Safety Standards for school buses.

TYPE B BUS



The TYPE B school bus consists of a bus body constructed and installed upon a front-section vehicle chassis, or stripped chassis, with a GVWR of more than 10,000 pounds, designed for carrying more than 10 with a GVWR of more than 10,000 pounds, designed for carrying persons. Part of the engine is beneath and/or behind the windshield and beside the driver's seat. The entrance door is behind the front wheels. TYPE B school buses meet all Federal Motor Vehicle Safety Standards for school buses.

TYPE C BUS



The TYPE C school bus, also known as a 'CONVENTIONAL,' is a body installed upon a flat-back cowl chassis with GVWR of more than 10,000 pounds, designed for carrying more than 10 persons. All of the engine is in front of the windshield and the entrance door is behind the front wheels. TYPE C school buses meet all Federal Motor Vehicle Safety Standards for school buses.

TYPE D BUS



The TYPE D school bus, a transit-style vehicle with its body installed upon a chassis, with the engine mounted in the front, midship, or rear with a GVWR rating of more than 10,000 pounds, and designed for carrying more than 10 persons. The engine may be behind the windshield and beside the driver's seat, it may be at the rear of the bus, behind the rear wheels; or midship between the front and rear axles. The entrance door is ahead of the front wheels. TYPE D school buses meet all Federal Motor Vehicle Safety Standards for school buses.

TERMS and ACROYNMS

ADA	Americans with Disabilities Act
AFV	Alternative Fuel Vehicle
ANPRM	Advanced Notice of Proposed Rule Making
ANSI	American National Standards Institute
ASTM	ASTM International (originally known as the American Society for Testing and Materials)
CAA	Clean Air Act
CDIP	Commercial Drivers Instructional Permit
CDL	Commercial Drivers License
CFR	Code of Federal Regulations
CMV	Commercial Motor Vehicle
CMVSA	Commercial Motor Vehicle Safety Act of 1986
CNG	Compressed Natural Gas
COWHAT	Committee on Wheelchairs and Transportation
CSRS	Child Safety Restraint System
DEF	Diesel Exhaust Fluid
DOC	Diesel Oxygenation Catalyst
DOT	United States Department of Transportation
DPF	Diesel Particulate Filter
DRL	Daytime Running Lamps
EGR	Exhaust Gas Recirculation
EHA	Education for all Handicapped Children Act
EOBR	Electronic On-Board Recorders
EPA	United State Environmental Protection Agency
FAPE	Free Appropriate Public Education
FERPA	Family Educational Rights and Privacy Act
FHWA	Federal Highway Administration, an agency of the U.S. Department of Transportation
FMSCA	Federal Motor Carrier Safety Administration
FMCSR	Federal Motor Carrier Safety Regulations
FMVSS	Federal Motor Vehicle Safety Standards
FSS	Fire suppressant system
FTA	Federal Transit Administration
GAWR	Gross Axle Weight Rating
GPS	Global Positioning Device
GVW	Gross Vehicle Weight
GVWR	Gross Vehicle Weight Rating
ICC	The former Interstate Commerce Commission
IDEA	Individuals with Disabilities Education Act
IEP	Individualized Education Program
IFSP	Individualized Family Service Plan
LED	Light Emitting Diodes
LEA	Local Education Authority

LNG	Liquefied Natural Gas
LPG	Liquefied Petroleum Gas, also known as propane.
LRE	Least Restrictive Environment
MFSAB	Multi-function School Activity Bus
MPV	Multipurpose Passenger Vehicle
NAPT	National Association for Pupil Transportation
NASDPTS	National Association of State Directors of Pupil Transportation Services
NCST	National Congress on School Transportation
NFPA	National Fire Protection Association
NGV	Natural Gas Vehicle
NHTSA	National Highway Traffic Safety Administration
NIST	National Institute of Standards and Technology
NOx	Oxides of Nitrogen
NPRM	Notice of Proposed Rule Making
NSBY	National School Bus Yellow
NSC	National Safety Council
NSTA	National School Transportation Association
NSTSP	National School Transportation Specifications and Procedures
NTSB	National Transportation Safety Board
OCR	Office of Civil Rights
OEM	Original Equipment Manufacturer
OSEP	Office of Special Education Programs
OSERS	Office of Special Education and Rehabilitative Services
OSHA	Occupational Safety and Health Administration
OTETA	Omnibus Transportation Employees Testing Act
PA SYSTEM	Public Address System
RESNA	Rehabilitation Engineering and Assistive Technology Society of North America
RFP	Requests for Proposals
SAE	Society of Automotive Engineers
SBMTC	School Bus Manufacturers Technical Council
SCR	Selective Catalyst Reduction
SOS Lights	Stop on Signal Lights
SOWAT	Subcommittee on Wheelchair and Transportation
TDD	Telecommunication Devices for the Deaf
TSA	Transportation Security Administration
UCRA	Universal Child Restraint Anchorage
ULSD	Ultra-Low Sulfur Diesel
UST	Underground Storage Tank.
VIN	Vehicle Identification Number
WTORS	Wheelchair Tiedown Occupant Restraint System
ZEB	Zero-Emissions Bus
ZEV	Zero-Emissions Vehicle

BUS BODY and CHASSIS STANDARDS

AIR CLEANER

- A. A dry element type air cleaner shall be provided.
- B. All diesel engine air filters shall include a latch-type restriction indicator that retains the maximum restriction developed during operation of the engine. The indicator should include a reset control so the indication can be returned to zero when desired.

AISLE

All emergency exit doors shall be accessible by a 12 inch minimum aisle. The aisle shall be unobstructed at all times by any type of barrier, seat, wheelchair or tie-down, unless a flip seat is installed and occupied. The track of a track seating system is exempt from this requirement. A flip seat in the unoccupied (up) position shall not obstruct the 12 inch minimum aisle to any side emergency exit door.

AXLES

The front and rear axle and suspension systems shall have a gross axle weight rating (GAWR) at ground commensurate with the respective front and rear weight loads of the bus loaded to the rated passenger capacity.

BACK-UP WARNING ALARM

An automatic audible alarm shall be installed behind the rear axle and shall comply with the published Backup Alarm Standards (SAE J994b), providing a minimum of 112 dBA, or shall have a variable volume feature that allows the alarm to vary from 87 dBA to 112 dBA sound level, staying at least 5 dBA above the ambient noise level.

BATTERY- SEE ELECTRICAL

BRAKES: GENERAL

- A. The chassis brake system shall conform to the provisions of FMVSS Nos. 105, *Hydraulic and Electric Brake Systems*, 106, *Brake Hoses*, and 121, *Air Brake Systems*, as applicable.
- B. The anti-lock brake system (ABS), provided in accordance with FMVSS No. 105 *Hydraulic and Electric Brake Systems* or No. 121, *Air Brake Systems*, shall provide wheel speed sensors for each front wheel and for each wheel on at least

one rear axle. The system shall provide anti-lock braking performance for each wheel equipped with sensors. (Four Channel System)

- C. All brake systems shall be designed to permit visual inspection of brake lining wear without removal of any chassis component(s).
- D. The brake lines, booster-assist lines, and control cables shall be protected from excessive heat, vibration and corrosion and installed in a manner which prevents chafing.
- E. The parking brake system for either air or hydraulic service brake systems may be of a power-assisted design. The power parking brake actuator should be a device located on the instrument panel within reach of a seated 5th percentile female driver. As an option, the parking brake may be set by placing the automatic transmission shift control mechanism in the “park” position.
- F. The power-operated parking brake system may be interlocked to the engine key switch. Once the parking brake has been set and the ignition switch turned to the “off” position, the parking brake cannot be released until the key switch is turned back to the on position.

BRAKES: HYDRAULIC

Buses using a hydraulic-assist brake shall be equipped with audible and visible warning signals that provide a continuous warning to the driver indicating a loss of fluid flow from the primary source or a failure of the back-up pump system.

BRAKES: AIR

- A. The air pressure supply system shall include a desiccant-type air dryer installed according to manufacturer’s recommendations. The air pressure storage tank system may incorporate an automatic drain valve.
- B. The chassis manufacturer shall provide an accessory outlet for air-operated systems installed by the body manufacturer. This outlet shall include a pressure protection valve to prevent loss of air pressure in the service brake reservoir.
- C. For air brake systems, an air pressure gage shall be provided in the instrument panel capable of complying with CDL pre-trip inspection requirements.
- D. Air brake-equipped buses may be equipped with a service brake interlock. If equipped with a service brake interlock, the parking brake cannot be released until the brake pedal is depressed.
- E. Air brake systems may include a system for anti-compounding of the service brakes and parking brakes.

- F. Air brakes shall have both a visible and audible warning device whenever the air pressure falls below the level where warnings are required under FMVSS No. 121, *Air Brake Systems*.

BUMPER: FRONT

- A. School buses shall be equipped with a front bumper.
- B. The front bumper on Type A-2 (with GVWR greater than 14,500 pounds), Type B, Type C, and Type D shall be equivalent in strength and durability to pressed steel channel at 3/16 inches thick and not less than 8 inches wide (high). It shall extend beyond the forward-most part of the body, grille, hood, and fenders and shall extend to outer edges of the fenders at the bumper's top line. Type A buses having a GVWR of 14,500 pounds or less may be equipped with an OEM-supplied front bumper. The front bumper shall be of sufficient strength to permit being pushed by another vehicle on a smooth surface with a 5 degree (8.7 percent) grade, without permanent distortion. The contact point on the front bumper is intended to be between the frame rails, with as wide a contact area as possible. If the front bumper is used for lifting, the contact points shall be under the bumper attachments to the frame rail brackets unless the manufacturer specifies different lifting points in the owner's manual. Contact and lifting pressures should be applied simultaneously at both lifting points.
- C. The front bumper, except breakaway bumper ends, shall be of sufficient strength to permit pushing a vehicle of equal gross vehicle weight, per Section B, without permanent distortion to the bumper, chassis, or body.
- E. The bumper shall be designed or reinforced so that it will not deform when the bus is lifted by a chain that is passed under the bumper (or through the bumper if holes are provided for this purpose) and attached to both tow hooks/eyes. For the purpose of meeting this specification, the bus shall be empty and positioned on a level, hard surface and both tow hooks/eyes shall share the load equally.

BUMPER: REAR

- A. The bumper on Type A-1 buses shall be a minimum of 8 inches wide (high). Bumpers on Types A-2, B, C and D buses shall be a minimum of 9½ inches wide (high). The bumper shall be of sufficient strength to permit being pushed by another vehicle of similar size and being lifted by the bumper without permanent distortion.
- B. The bumper shall wrap around the back corners of the bus. It shall extend forward at least 12 inches, measured from the rear-most point of the body at the floor line, and shall be mounted flush with the sides of the body or protected with an end panel.

- C. The bumper shall be attached to the chassis frame in such a manner that it may be removed. It shall be braced to resist deformation of the bumper resulting from impact from the rear or the side. It shall be designed to discourage hitching of rides by an individual.
- D. The bumper shall extend at least 1 inch beyond the rear-most part of the body surface, measured at the floor line.
- E. The bottom of the rear bumper shall not be more than 30 inches above ground level.
- F. The bumper shall be designed or reinforced so that it will not deform when the bus is lifted by a chain that is passed under the bumper (or through the bumper if holes are provided for this purpose) and attached to both tow eyes. For purpose of meeting this specification, the bus shall be empty and positioned on a level, hard surface and both tow hooks/eyes shall share the load equally.

CEILING - SEE INSULATION and INTERIOR

CERTIFICATION

Upon request of the agency having student transportation jurisdiction, the chassis and body manufacturer(s) shall certify that their product(s) meets the state's minimum standards on items not covered by FMVSS certification requirements of 49 CFR, Part 567 Certification.

CLUTCH

- A. Clutch torque capacity shall be equal to or greater than the engine torque output.
- B. A starter interlock shall be installed to prevent actuation of the starter if the clutch pedal is not depressed.

COLOR

- A. The school bus shall be painted National School Bus Yellow (NSBY). (See APPENDIX B.)
- B. The body exterior trim shall be black, NSBY or green (for hybrid buses). If used, demountable rims may be silver, gray, white, yellow, green or black, (as received from the wheel manufacturer).

- C. Except for the vertical portion of the front and rear roof caps, the roof of the bus may be painted white. (See illustration in APPENDIX B, Placement of Retro-reflective Markings.)
- D. MFSABs shall be exempt from these color requirements.

CONSTRUCTION

- A. **Side Intrusion Test:** The bus body shall be constructed to withstand an intrusion force equal to the curb weight of the vehicle or 20,000 pounds, whichever is less. Each vehicle shall be capable of meeting this requirement when tested in accordance with the procedures set forth below. The complete body structure, or a representative seven-body section mock up with seats installed, shall be load-tested at a location 23 ± 2 inches above the floor line, with a maximum 10 inch diameter cylinder, 48 inches long, mounted in a horizontal plane.

The cylinder shall be placed as close as practical to the mid-point of the tested structure, spanning two internal vertical structural members. The cylinder shall be statically loaded to the required force of curb weight of 20,000 pounds, whichever is less, in a horizontal plane with the load applied from the exterior toward the interior of the test structure. When the minimum load has been applied, the penetration of the loading cylinder into the passenger compartment shall not exceed 10 inches from its original point of contact. There can be no separation of lapped panels or construction joints. Punctures, tears or breaks in the external panels are acceptable but are not permitted on any adjacent interior panel. Body companies shall certify compliance with this intrusion requirement, and include test results, as requested.

- B. Construction shall be reasonable dust-proof and watertight.

CROSSING CONTROL ARM (This school bus standard applies to all school buses EXCEPT those used solely to transport students with special needs who are manually loaded and unloaded.)

- A. School buses shall be equipped with a crossing control arm mounted on the right side of the front bumper. When opened, this arm shall extend in a line parallel to the body side and aligned with the right side wheel.
- B. All components of the crossing control arm and all connections shall be weatherproofed.
- C. The crossing control arm shall incorporate system connectors (electrical, vacuum, or air) at the gate and shall be easily removable to allow for towing of the bus.

- D. The crossing control arm shall be constructed of non-corrodible or nonferrous material, or treated in accordance with the body sheet metal specification. (See Metal Treatment.)
- E. There shall be no sharp edges or projections that could cause injury or be a hazard to students. The end of the arm shall be rounded.
- F. The crossing control arm shall extend minimum 70 inches (measured from the bumper at the arm assembly attachment point) when in the extended position. The crossing control arm shall not extend past the end of the bumper when in the stowed position.
- G. The crossing control arm shall extend simultaneously with the stop arm activated by stop arm controls.
- H. An automatic recycling interrupt switch may be installed for temporarily disabling of the crossing control arm.
- I. The assembly may include a device attached to the bumper near the end of the arm to automatically retain the arm while in the stowed position. That device shall not interfere with normal operations of the crossing control arm.

DEFROSTERS

- A. Defrosting and defogging equipment shall direct a sufficient flow of heated air onto the windshield, the window to the left of the driver and the glass in the viewing area directly to the right of the driver to eliminate frost, fog and snow. (Exception: The requirements of this standard do not apply to the exterior surfaces of double pane storm windows.)
- B. The defrosting system shall conform to SAE J381, *Windshield Defrosting Systems Test Procedure and Performance Requirements-Trucks, Buses, and Multipurpose Vehicles*.
- C. The defroster and defogging system shall be capable of furnishing heated, outside ambient air, except the part of the system furnishing additional air to the windshield, entrance door and step well may be of the re-circulating air type.
- D. Auxiliary fans are not considered defrosting or defogging systems.
- E. Portable heaters shall not be used.

DOORS

- A. The entrance door shall be under the driver's control, designed to afford easy release and to provide a positive latching device on manual operating doors to prevent accidental opening. When a hand lever is used, no part shall come together that will shear or crush fingers. Manual door controls shall not require more than 25 pounds of force to operate at any point throughout the range of operation, as tested on a 10 percent grade, both uphill and downhill.
- B. The entrance door shall be located on the right side of the bus, opposite and within direct view of driver.
- C. The entrance door shall have a minimum horizontal opening of 24 inches and a minimum vertical opening of 68 inches.
- D. The entrance door shall be a split-type door and shall open outward.
- E. All entrance door glass shall be of approved safety glass. The bottom of each lower glass panel shall not be more than 10 inches from the top surface of the bottom step. The top of each upper glass panel when viewed from the interior shall be not more than 3 inches below the interior door control cover or header pad.
- F. Vertical closing edges on entrance doors shall be equipped with flexible material.
- G. All door openings shall be equipped with padding at the top edge of the opening. Padding shall be at least 3 inches wide and 1 inch thick and extend the full width of the door opening.
- H. On power-operated entrance doors, the emergency release valve, switch or device to release the entrance door must be placed above or to the immediate left or immediate right of the entrance door and clearly labeled. The emergency release valve, switch or device shall work in the absence of power.

DRIVE SHAFT

The drive shaft shall be protected by a metal guard or guards around the circumference of the drive shaft to reduce the possibility of its whipping through the floor or dropping to the ground, if broken.

ELECTRICAL SYSTEM

A. Battery

1. The storage battery shall have a minimum cold cranking capacity rating (cold cranking amps) equal to the cranking current required for 30 seconds at 0 degrees Fahrenheit and a minimum reserve capacity rating of 120 minutes at 25 amps. Higher capacities may be required, depending upon optional equipment and local environmental conditions.
2. The manufacturer shall securely attach the battery on a slide-out or swing-out tray in a closed, vented compartment in the body skirt so that the battery is accessible for convenient servicing from the outside. When in the stored position, the tray shall be retained by a securing mechanism capable of holding the tray (with battery(ies)) in position when subjected to a 5g load from any direction. The battery compartment door or cover if separate from the tray shall be hinged at the front or top. It shall be secured by a positive operated latching system or other type fastener. The door may be an integral part of the battery slide tray. The door or cover must fit tightly to the body, and not present sharp edges or snagging points. Battery cables shall meet SAE requirements. Battery cables shall be of sufficient length to allow the battery tray to fully extend. The battery compartment is required on Type A-1 diesel buses, and any battery(ies) mounted on the frame by the chassis manufacturer shall be relocated to the battery compartment.
3. All batteries are to be secured in a sliding tray except van conversions or cutaway front-section chassis may be secured in accordance with the manufacturer's standard configuration. In these cases, the final location of the battery and the appropriate cable lengths shall be mutually agreed upon by the chassis and body manufacturers. However, in all cases the battery cable provided with the chassis shall have sufficient length to allow some slack, and be of sufficient gauge to carry the required amperage.
4. Buses may be equipped with a battery shut-off switch. The switch is to be placed in a location not readily accessible to the driver or passengers.

B. Alternator

1. All A-2 buses and Type B buses with a GVWR of 15,000 pounds or less shall have a minimum 130-amp alternator.
2. All buses over 15,000 pounds GVWR shall be equipped with a heavy-duty truck or bus type alternator having a minimum output rating of 160 amps

or higher, and should produce a minimum current output of 50 percent of the rating at engine idle speed.

3. Buses equipped with an electrically powered wheelchair lift, air conditioning or other accessories, may be equipped with a device that monitors the electrical system voltage and advances the engine idle speed when the voltage drops to, or below, a pre-set level.
4. A belt driven alternator shall be capable of handling the rated capacity of the alternator with no detrimental effect on any other driven components. (For estimating required alternator capacity, see *School Bus Manufacturers Technical Council's publication, "School Bus Technical Reference,"* available at <http://www.nasdpts.org>.)
5. A direct-drive alternator is permissible in lieu of a belt-driven alternator.

C. Electrical Components

Materials in all electrical components shall contain no mercury.

D. Wiring, Chassis

1. All wiring shall conform to current applicable recommended practices of the Society of Automotive Engineers (SAE). All wiring shall use color and at least one other method of identification. The other method shall be either a number code or name code, and each chassis shall be delivered with a wiring diagram that illustrates the wiring of the chassis.
2. Chassis manufacturer of an incomplete vehicle shall install a readily accessible terminal strip or plug on the body side of the cowl or in an accessible location in the engine compartment of vehicles designed without a cowl. The strip or connector shall contain the following terminals for the body connections:
 - a. Main 100 amp body circuit;
 - b. Tail lamps;
 - c. Right turn signal;
 - d. Left turn signal;
 - e. Stop lamps;
 - f. Back up lamps; and

- g. Instrument panel lights (controlled by dimmer switch).
- 3. An appropriate identifying diagram (color plus a name or number code) for all chassis electric circuits shall be provided to the body manufacturer for distribution to the end user.
- 4. Wiring for the headlamp system must be separate from the electronic controlled body solenoid/module.

E. Wiring, Body

- 1. All wiring shall conform to current SAE standards.
- 2. All wiring shall have an amperage capacity exceeding the design load by at least 25 percent. All wiring splices are to be accessible and noted as splices on the wiring diagram.
- 3. A body wiring diagram, sized to be easily read, shall be furnished with each bus body or affixed to an area convenient to the electrical accessory control panel.
- 4. The body power wire shall be attached to a special terminal on the chassis.
- 5. Each wire passing through metal openings shall be protected by a grommet.
- 6. Wires not enclosed within the body shall be fastened securely at intervals of not more than 18 inches. All joints shall be soldered or joined by equally effective connectors, which shall be water-resistant and corrosion-resistant.
- 7. Wiring shall be arranged in circuits, as required, with each circuit protected by a fuse or electronic protection device. A system of color and number-coding shall be used and an appropriate identifying diagram shall be provided to the end user, along with the wiring diagram provided by the chassis manufacturer. The wiring diagrams shall be specific to the bus model supplied and shall include any changes to wiring made by the body manufacturer. Chassis wiring diagrams shall also be supplied to the end user. The following body interconnecting circuits shall be color-coded, as noted:

FUNCTION	COLOR
Left Rear Directional Light	Yellow
Right Rear Directional Light	Dark Green
Stoplights	Red
Back-up lights	Blue

Tail Lamps	Brown
Ground	White
Ignition Feed, Primary Feed	Black

The color of cables shall correspond to SAE J 1128, *Low-Tension Primary Cable*.

8. Wiring shall be arranged in at least 6 regular circuits, as follows:
 - a. Head, tail, and stop (brake), clearance and instrument panel lamps;
 - b. Step well lamps shall be actuated when the entrance door is open;
 - c. Dome lamp;
 - d. Ignition and emergency door signal;
 - e. Turn signal lamps; and
 - f. Alternately flashing signal lamps.
 9. Any of the above combination circuits may be subdivided into additional independent circuits.
 10. Heaters and defrosters shall be wired on an independent circuit.
 11. Whenever possible, all other electrical functions (such as sanders and electric type windshield wipers) shall be provided with independent and properly protected circuits.
 12. Each body circuit shall be coded by number or letter on a diagram of circuits and shall be attached to the body in a readily accessible location.
- F. Buses may be equipped with a 12-volt power port in the driver's area.
- G. There shall be a manual noise suppression switch installed in the control panel. The switch shall be labeled and alternately colored. This switch shall be an on/off type that deactivates body equipment that produces noise, including, at least, the AM/FM radio, heaters, air conditioners, fans and defrosters. This switch shall not deactivate safety systems, such as windshield wipers or lighting systems.
- H. The entire electrical system of the body shall be designed for the same voltage as the chassis on which the body is mounted.

EMERGENCY EQUIPMENT

A. Fire Extinguisher:

1. The bus shall be equipped with at least one 5 or 6 pound UL-approved pressurized, dry chemical fire extinguisher. The extinguisher shall be secured in a mounted bracket, located in the driver's compartment and readily accessible to the driver and passengers. A pressure gauge shall be mounted on the extinguisher and be easily read without moving the extinguisher from its mounted position.
2. The fire extinguisher shall have a total rating of two A:10-BC, or greater. The operating mechanism shall be secured with a type of seal that will not interfere with the use of the fire extinguisher.

B. First Aid Kit

The bus shall have a removable, moisture-proof and dust-proof first aid kit in an accessible place in the driver's compartment. It shall be mounted and identified as a first aid kit. The location for the first aid kit shall be marked.

Minimum contents include:

- 2- 1 inch x 2 ½ yards adhesive tape rolls
- 24- Sterile gauze pads 3 x 3 inches
- 50- ¾ x 3 inches adhesive bandages
- 8- 2 inch bandage compress
- 10- 3 inch bandage compress
- 2- 2 inch x 6 feet sterile gauze roller bandages
- 2- Non-sterile triangular bandages, minimum 39x35x54 inches with 2 safety pins
- 3- Sterile gauze pads 36x36 inches
- 3- Sterile eye pads
- 1- Rounded-end scissors
- 1- Pair of medical grade gloves
- 1- Mouth-to-mouth airway;

C. Body Fluid Clean-Up Kit

Each school bus shall have a removable, moisture proof, sealed body fluid clean-up kit accessible to the driver. It shall be mounted and identified as a body fluid clean-up kit.

Minimum contents include:

- 1- Packet of a solution that is used to solidify bodily fluids
- 2- Antiseptic wipes or antiseptic liquid
- 1- Antimicrobial wipe for washing hands
- 1- Disposal germicidal wipes
- 1- Pair of medical grade gloves
- 1- Safety shield
- 1- Red bag that is marked "biohazard"
- 1- Scraper/scooper

D. Warning Devices

Each school bus shall contain at least three retro-reflective triangle road warning devices that meet the requirements of FMVSS No. 125, *Warning Devices*. They shall be mounted in an accessible place.

- E. Any piece of emergency equipment must be secured. First Aid and Body Fluid kits must be mounted in an enclosed compartment labeled in not less than 1 inch letters, indentifying each piece of equipment contained therein.

EMERGENCY EXITS

- A. Any installed emergency exit shall comply with the design and performance requirements of FMVSS No. 217, *Bus Emergency Exits and Window Retention and Release*, applicable to that type of exit, regardless of whether or not that exit is required by FMVSS No. 217.

B. Emergency Window Requirements

- 1. The rear emergency window shall have a lifting assistance device that will aid in lifting and holding the rear emergency window open.
- 2. Side emergency exit windows, when installed, may be vertically hinged on the forward side of the window. No side emergency exit window will be located above a stop arm.

C. Emergency Door Requirements

- 1. The upper portion of the emergency door shall be equipped with approved safety glazing, the exposed area of which shall be at least 400 square inches. The lower portion of the rear emergency doors on Types A-2, B, C and D vehicles shall be equipped with a minimum of 350 square inches of approved safety glazing.

2. There shall be no steps leading to an emergency door except on Types C and D all-wheel drive buses.
3. Padding shall be affixed to the top edge of each emergency door opening. Padding shall be at least 3 inches wide and 1 inch thick and shall extend the full width of the door opening.
4. There shall be no obstruction higher than 1/4 inch across the bottom of any emergency door opening. Fasteners used within the emergency exit opening shall be free of sharp edges or burrs.

D. Emergency Exit Requirements

1. Types A, B, C and D vehicles shall be equipped with a total number of emergency exits as follows for the indicated capacities of vehicles. Exits required by FMVSS No. 217 may be included to comprise the total number of exits specified.
 - a. 0 to 42 Passenger = 1 emergency exit per side and 1 roof hatch.
 - b. 43 to 78 Passenger = 2 emergency exits per side and 2 roof hatches.
 - c. 79 to 90 Passenger = 3 emergency exits per side and 2 roof hatches.
2. Side emergency exit windows when installed may vertically hinge on the forward side of the window. No side emergency exit window will be located above a stop arm.

EXHAUST SYSTEM

- A. The exhaust pipe, after-treatment system, and tailpipe shall be outside the bus body compartment and shall be attached to the chassis so any other chassis component is not damaged.
- B. The tailpipe and after-treatment system shall be constructed of a corrosion-resistant tubing material at least equal in strength and durability to 16-gauge steel tubing of equal diameter.
- C. The tailpipe may be flush with, or shall not extend more than 2 inches beyond, the perimeter of the body for side-exit pipe or the bumper for rear-exit pipe. The exhaust system shall be designed such that exhaust gas will not be trapped under the body of the bus.
- D. The tailpipe shall exit to the left or right of the emergency exit door in the rear of the vehicle or to the left side of the bus in front of or behind the rear drive axle. The tailpipe exit location on all Types A-1 or B-1 buses may be in accordance to

the manufacturer's standards. The tailpipe shall not exit beneath any fuel filler location, emergency door or lift door.

- E. The exhaust system shall be in a manner to prevent any damage to any fuel system component.
- F. The design of the after treatment systems shall not allow active (non-manual) regeneration of the particulate filter during the loading and unloading of passengers. Manual regeneration systems will be designed such that unintentional operation will not occur.
- G. For after treatment systems that require Diesel Exhaust Fluid (DEF) to meet federally mandated emissions:
 - 1. The composition of Diesel Exhaust Fluid (DEF) must comply with International Standards ISO 22241-1. Refer to engine manufacturer for any additional DEF requirements.
 - 2. The DEF supply tank should be designed to meet a minimum ration of three diesel fills to one DEF fill.

FENDERS: FRONT

- A. When measured at the fender line, the total spread of outer edges of front fenders shall exceed total spread of front tires when front wheels are in straight-ahead position.
- B. Front fenders shall be properly braced and shall not require attachment to any part of the body.

FIRE SUPPRESSION SYSTEMS (Optional)

- A. The chassis manufacturer may provide an automatic fire extinguisher system in the engine compartment.
- B. Fire suppression system nozzles shall be located in the engine compartment, under the bus, in the electrical panel or under the dash, but they shall not be located in the passenger compartment. The system must include a lamp or buzzer to alert the driver that the system has been activated.

FLOORS

- A. The floor in under-seat area, including tops of wheel housings, driver's compartment and toeboard, shall be covered with an elastomeric floor covering, having a minimum over all thickness of 1/8 inch and a calculated burn rate of 0.1

or less, using the test methods, procedures and formulas listed in FMVSS No. 302, *Flammability of Interior Materials*. The driver's area and toeboard area in all Type-A buses may be manufacturer's standard flooring and floor covering.

- B. The floor covering in the aisles shall be ribbed or other raised pattern elastomer and have a calculated burn rate of 0.1 or less using the test methods, procedures and formulas listed in FMVSS No. 302. Minimum overall thickness shall be 3/16 inch measured from tops of ribs.
- C. The floor covering must be permanently bonded to the floor and must not crack when subjected to sudden changes in temperature. Bonding or adhesive material shall be waterproof and shall be a type recommended by the manufacturer of floor-covering material. All seams must be sealed with waterproof sealer.
- D. On Types B, C and D buses, a flush-mounted, screw-down plate that is secured and sealed shall be provided to access the fuel tank sending unit and/or fuel pump. This plate shall not be installed under flooring material.

FRAME

- A. Frame lengths shall be established in accordance with the design criteria for the complete vehicle.
- B. Making holes in top or bottom flanges or side units of the frame and welding to the frame shall not be permitted except as provided or accepted by the chassis manufacturer.
- C. Frames shall not be modified for the purpose of extending the wheel base.
- D. Any secondary manufacturer that modifies the original chassis frame shall provide a warranty at least equal to the warranty offered by the original equipment manufacturer (OEM), and shall certify that the modification and other parts or equipment affected by the modification shall be free from defects in material and workmanship under normal use and service intended by the OEM.

FUEL SYSTEM

- A. Fuel tank(s) having a minimum 30-gallon capacity shall be provided by the chassis manufacturer. Each tank shall be filled and vented to the outside of the passenger compartment, and each fuel filler should be placed in a location where accidental fuel spillage will not drip or drain on any part of the exhaust system.
- B. The fuel system shall comply with FMVSS No. 301, *Fuel System Integrity*.
- C. Fuel tank(s) may be mounted between the chassis frame rails or outboard of the frame rails on either the left or right side of the vehicle.

- D. The actual draw capacity of each fuel tank shall be a minimum of 83 percent of the tank capacity.
- E. Installation of alternative fuel systems, including fuel tanks and piping from the tank to the engine, shall comply with all applicable fire codes in effect on the date of manufacture of the bus.
- F. Installation of Liquefied Petroleum Gas (LPG) tanks shall comply with National Fire Protection Association (NFPA) 58, *Liquefied Petroleum Gas Code*.
- G. Installation of Compressed Natural Gas (CNG) containers shall comply with FMVSS No. 304, *Compressed Natural Gas Fuel Container Integrity*.
- H. The CNG Fuel System shall comply with FMVSS No. 303, *Fuel System Integrity of Compressed Natural Gas Vehicles*.

GOVERNOR

An electronic engine speed limiter shall be provided and set to limit engine speed, not to exceed the maximum revolutions per minute, as recommended by the engine manufacturer.

HANDRAILS

At least one handrail shall be installed. The handrail(s) shall assist passengers during entry or exit, and shall be designed to prevent entanglement, as evidenced by the passing of the NHTSA string and nut test.

HEATING SYSTEM, PROVISION FOR

The chassis engine shall have plugged openings for the purpose of supplying hot water for the bus heating system. The engine shall be capable of supplying coolant at a temperature of at least 170 degrees Fahrenheit at the engine coolant thermostat opening. The coolant flow rate shall be 50 pounds per minute at the return end of 30 feet of one inch inside diameter automotive hot water heater hose. (SEE SBMTC-001, *Standard Code for Testing and Rating Automotive Bus Hot Water Heating and Ventilating Equipment*)

HEATING and AIR CONDITIONING SYSTEMS

A. Heating System

1. The heater shall be hot water and/or combustion type.

2. If only one heater is used, it shall be fresh-air or combination fresh-air and re-circulation type.
3. If more than one heater is used, additional heaters may be re-circulating air type.
4. The heating system shall be capable of maintaining bus interior temperatures, as specified in test procedure SAE J2233.
5. Auxiliary fuel-fired heating systems are permitted, provided they comply with the following:
 - a. The auxiliary heating system shall utilize the same type fuel as specified for the vehicle engine;
 - b. The heater(s) may be direct, hot air-type or may be connected to the engine coolant system;
 - c. An auxiliary heating system, when connected to the engine coolant system, may be used to preheat the engine coolant or preheat and add supplementary heat to the heating system;
 - d. Auxiliary heating systems must be installed pursuant to the manufacturer's recommendations and shall not direct exhaust in such a manner that will endanger bus passengers;
 - e. All combustion heaters shall be in compliance with current FMCSA Regulations;
 - f. The auxiliary heating system shall require low voltage.
 - g. Auxiliary heating systems shall comply with FMVSS No. 301, *Fuel System Integrity*, and all other applicable FMVSS, as well as with SAE test procedures.
6. All forced-air heaters installed by body manufacturers shall bear a name plate that indicates the heater rating in accordance with SBMTC-001, *Standard Code for Testing & Rating Automotive Bus Hot Water Heating and Ventilating Equipment*. The plate shall be affixed by the heater manufacturer and shall constitute certification that the heater performance is as shown on the plate.
7. Heater hoses shall be adequately supported to guard against excessive wear due to vibration. The hoses shall not dangle or rub against the chassis or any sharp edges and shall not interfere with or restrict the operation of any engine function. Heater hoses shall conform to SAE

J20c, *Coolant System Hoses*. Heater lines on the interior of the bus shall be shielded to prevent scalding of the driver or passengers.

8. Each hot water system installed by a body manufacturer shall include one shut-off valve in the pressure line and one shut-off valve in the return line, with both valves at the engine in an accessible location, except that on Types A and B buses the valves may be installed in another accessible location.
9. All heaters in the passenger compartment shall be equipped with a device installed in the hot water pressure line, which regulates the water flow to all passenger heaters. The device shall be conveniently operated by the driver while seated. The driver and passenger heaters may operate independently of each other for maximum comfort.
10. Accessible bleeder valves for removing air from the heater shall be installed in an appropriate place in the return lines of body company-installed heater.
11. Access panels shall be provided to make heater motors, cores and fans readily accessible for service. An exterior access panel to the driver's heater may be provided.

B. Passenger Compartment Air Conditioning (Optional)

The following specifications are applicable to all types of school buses that may be equipped with air conditioning. This section is divided into two parts. Part 1 covers performance specifications, Part 2 covers test conditions and Part 3 covers other requirements applicable to all buses.

1. Performance Specifications

a. Standard Performance:

The installed air conditioning system should cool the interior of the bus from 100 degrees to 80 degrees Fahrenheit, measured at three points (minimum) located four feet above the floor on the longitudinal centerline of the bus. The three required points shall be: (1) three feet above the center point of the horizontal driver seat surface, (2) at the longitudinal midpoint of the body, and (3) three feet forward of the rear emergency door or, for Type D rear-engine buses, three feet forward of the end of the aisle. Note for the Type A vehicles placement of the rear thermocouple should be centered in the bus over the rear axle. The independent temperature reading of each temperature probe inside the bus shall

be within a range of +/- 3 degrees Fahrenheit of the average temperature at the conclusion of the test.

b. High Performance:

The installed air conditioning system should cool the interior of the bus from 100 degrees to 70 degrees Fahrenheit, measured at three points (minimum) located four feet above the floor on the longitudinal centerline of the bus. The three required points shall be: (1) three feet above the center point of the horizontal driver seat surface, (2) at the longitudinal midpoint of the body, and (3) three feet forward of the rear emergency door or, for Type-D rear-engine buses, three feet forward of the end of the aisle. Note for the Type A vehicles placement of the rear thermocouple should be centered in the bus over the rear axle. The independent temperature reading of each temperature probe inside the bus shall be within a range of +/- 3 degrees Fahrenheit of the average temperature at the conclusion of the test.

2. Test Conditions

The test conditions under which the above performance must be achieved shall consist of (1) placing the bus in a room (such as a paint booth) where ambient temperature can be maintained at 100 degrees Fahrenheit; (2) heat-soaking the bus at 100 degrees Fahrenheit at a point measured 2 feet horizontally from the top of the windows on both sides of the bus, with windows open for two hours; and (3) closing windows, turning on the air conditioner with engine running at 1250 +/- 50 RPM, and cooling the interior of the bus to 80 degrees Fahrenheit (standard performance) or 70 degrees Fahrenheit (high performance), within 30 minutes while maintaining 100 degrees Fahrenheit outside temperature.

The manufacturer shall provide facilities for the user or user's representative to confirm that a pilot model of each bus design meets the above performance requirements.

2. Other requirements

- a. Evaporator cases, lines and ducting (as equipped) shall be designed in such a manner that all condensation is effectively drained to the exterior of the bus below the floor level under all conditions of vehicle movement and without leakage on any interior portion of bus;
- b. Evaporators and ducting systems shall be designed and installed to be free of projections or sharp edges. Ductwork shall be installed

so that exposed edges face the front of the bus and do not present sharp edges;

- c. On school buses equipped with Type-2 seatbelts having anchorages above the windows, the ducting (if used) shall be placed at a height sufficient to not obstruct occupant securement anchorages. This clearance shall be provided along the entire length (except at evaporator locations) of the passenger area on both sides of the bus interior;
- d. The body may be equipped with insulation, including sidewalls, roof, firewall, rear, inside body bows and plywood or composite floor insulation to reduce thermal transfer;
- e. All glass (windshield, service and emergency doors, side and rear windows) may be equipped with maximum integral tinting allowed by federal, state, or ANSI standards for respective locations, except that windows rear of the driver's compartment, if tinted, shall have approximately 28 percent light transmission;
- f. Electrical generating capacity shall be provided to accommodate the additional electrical demands imposed by the air conditioning system;
- g. Roofs may be painted white to aid in heat dissipation. (See APPENDIX B); and
- h. Air intake for any evaporator assembly(ies), except for front evaporator of Type A-1, shall be equipped with replaceable air filter(s) accessible without disassembly of evaporator case.
- i. For all buses (except Type D rear engine transit) equipped with a rear evaporator assembly, evaporator shall not encroach upon head impact zone, but may occupy an area of less than 26.5 inches from the rear wall and 14 inches from the ceiling.
- j. For Type D rear engine transit buses equipped with a rear evaporator over the davenport, the evaporator assembly may not interfere with rear exit window and may not extend above the rear seating row.

HINGES

All exterior metal door hinges which shall be designed to allow lubrication to be channeled to the center 75 percent of each hinge loop without disassembly, unless they are constructed of stainless steel, brass or non-metallic hinge pins or other designs that prevent corrosion.

HORN

The bus shall be equipped with a horn(s) of standard make with the horn(s) capable of producing a complex sound in bands of audio frequencies between 250 and 2,000 cycles per second and tested in accordance with SAE J-377, *Horn-Forward Warning-Electric-Performance, Test and Application*.

IDENTIFICATION

- A. The body shall bear words "SCHOOL BUS" in black letters at least 8 inches high on both front and rear of the body or on signs attached thereto. Lettering shall be placed as high as possible without impairment of its visibility. Letters shall conform to "Series B" of Standard Alphabets for Highway Signs. "SCHOOL BUS" lettering shall have a reflective background, or as an option, may be illuminated by backlighting. MFSABs are exempt from these requirements.
- B. Required lettering and numbering shall include:
 - 1. District, company name or owner of the bus displayed at the beltline.
 - 2. The bus identification number displayed on the sides, on the rear and on the front.
- C. Other lettering, numbering or symbols which may be displayed on the exterior of the bus shall be limited to:
 - 1. Bus identification number, minimum 12 inch high characters, on the top of the bus, in addition to required numbering on sides, rear, and front;
 - 2. The location of the battery(ies) identified by the word "BATTERY" or "BATTERIES" on the battery compartment door in 2 inch lettering;
 - 3. Symbols or letters not to exceed 64 square inches of total display near the entrance door, displaying information for identification by the students of the bus or route served;
 - 4. Manufacturer, dealer or school identification or logos;
 - 5. Symbols identifying the bus as equipped for or transporting students with special needs is noted in SPECIFICALLY EQUIPPED SCHOOL BUS SPECIFICATIONS;
 - 6. Lettering on the rear of the bus relating to school bus flashing signal lamps or railroad stop procedures; and

7. Identification of fuel type shall be in 2 inch lettering adjacent to the fuel filler opening.

INSIDE HEIGHT

Inside body height shall be 72 inches or more, measured metal to metal, at any point on the longitudinal centerline from the front vertical bow or rear vertical bow. Inside body height of Type A-1 buses shall be 62 inches or more. Inside height does not apply to air conditioning equipment.

INSTRUMENTS AND INSTRUMENT PANEL

- A. The chassis shall be equipped with the following instruments and gauges listed below: (Telltale warning lamps in lieu of gauges are not acceptable, except as noted):
 1. Speedometer;
 2. Odometer that can be read without using a key and that will give accrued mileage (to seven digits), including tenths of miles, unless tenths of miles are registered on a trip odometer.
 3. Tachometer (**Note:** For types B, C and D buses, a tachometer shall be installed so as to be visible to the driver while seated in a normal driving position.);
 4. Voltmeter (**Note:** An ammeter with graduated charge and discharge indications is permitted in lieu of a voltmeter; however, when used, the ammeter wiring must be compatible with the current flow of the system.);
 5. Oil pressure gauge;
 6. Water temperature gauge;
 7. Fuel gauge;
 8. Upper beam headlamp indicator;
 9. Brake air pressure gauge (air brakes), brake indicator lamp (vacuum/hydraulic brakes), or brake indicator lamp (hydraulic/hydraulic);
 10. Turn signal indicator; and
 11. Glow-plug indicator lamp, where appropriate.
- B. All instruments shall be easily accessible for maintenance and repair.

- C. The instruments and gauges shall be mounted on the instrument panel so that each is clearly visible to the driver while seated in a normal driving position.
- D. Instruments and controls must be illuminated as required by FMVSS No. 101, *Controls and Displays*.
- E. Multi-function gauge (MFG)
 - 1. The driver must be able to manually select any displayable function of the gauge on a MFG, whenever desired.
 - 2. Whenever an out-of-limits condition that would be displayed on one or more functions of a MFG occurs, the MFG controller should automatically display this condition on the instrument cluster. This should be in the form of an illuminated telltale warning lamp, as well as having the MFG automatically display the out-of-limits indications. If two or more functions displayed on the MFG go out of limits simultaneously, then the MFG should sequence automatically between those functions continuously until the condition(s) is corrected.
 - 3. The use of a MFG does not relieve the need for audible warning devices, where required.

INSULATION (optional)

- A. If thermal insulation is specified, it shall be fire-resistant, UL approved, with minimum R-value of 5.5. Insulation shall be installed to prevent sagging.
- B. If floor insulation is required, it shall be 5-ply softwood plywood, nominal 5/8 inch thickness and shall equal to or exceed properties of the exterior-type softwood plywood, C-D Grade, as specified in standard issued by U.S. Department of Commerce. When plywood is used, all exposed edges shall be sealed. Type A-1 buses may be equipped with nominal 1/2 inch-thick plywood or equivalent material meeting above requirements. Equivalent material may be used to replace plywood, provided it has equal or greater insulation R-value, sound abatement, deterioration-resistant and moisture-resistant properties.

INTERIOR

- A. The interior of bus shall be free of all unnecessary projections, which include luggage racks and attendant handrails, to minimize the potential for injury. This specification requires inner lining on ceilings and walls. If the ceiling is constructed with lap joints, the forward panel shall be lapped by rear panel and exposed edges shall be beaded, hemmed, flanged, or otherwise treated to

- B. Interior overhead storage compartments may be provided if they meet the following criteria:
 - 1. Head protection requirements of FMVSS No. 222, *School Bus Passenger Seating and Crash Protection*, where applicable;
 - 2. Be completely enclosed and equipped with latching door (both door and latch sufficient to withstand a pushing force of 50 pounds applied at the inside center of the door).
 - 3. Have all corners and edges rounded with a minimum radius of 1 inch or be padded equivalent to door header padding;
 - 4. Be attached to the bus sufficiently to withstand a force of equal to 20 times the maximum rated capacity of the compartment; and
 - 5. Have no protrusions greater than ¼ inch.
- C. The driver's area forward of the foremost padded barriers will permit the mounting of required safety equipment and vehicle operation equipment.
- D. Every school bus shall be constructed so that the noise level at the ear of the occupant nearest to the primary vehicle noise source shall not exceed 85 dBA when tested according to the procedure found in APPENDIX B.

LAMPS and SIGNALS

- A. Interior lamps which illuminate the aisle and the step well shall be provided. The step well lamp shall be illuminated by an entrance door-operated switch, to illuminate only when headlights and clearance lamps are on and the entrance door is open.
- B. Body instrument panel lamps shall be controlled by an independent dimmer switch or may be controlled by the dimmer that operates the gauge lighting.
- C. School bus alternately flashing signal lamps shall be provided, as described by law. MFSAB's are exempt from this requirement.
 - 1. The bus shall be equipped with two red lamps at the rear of vehicle and two red lamps at the front of the vehicle.
 - 2. In addition to the four red lamps described above, four amber lamps shall be installed so that one amber lamp is located near each red signal lamp, at

the same level, but closer to the vertical centerline of bus. The system of red and amber signal lamps shall be wired so that amber lamps are energized manually. The red lamps are automatically energized and amber lamps are automatically de-energized when stop signal arms are extended or when the bus entrance door is opened.

The above mentioned activation sequence can be accomplished with a non-sequential operation warning lamp system.

3. Red lamps shall flash at any time the stop signal arm is extended.
4. All flashers for alternately flashing red and amber signal lamps shall be enclosed in the body in a readily accessible location.

D. Turn signal and stop/tail lamps

1. The bus body shall be equipped with amber rear turn signal lamps that are at least 7 inches in diameter or, if a shape other than round, a minimum 38 square inches of illumination area and meet FMVSS No. 108, *Lamps, Reflective Devices, and Associated Equipment*. These signal lamps must be connected to the chassis hazard warning switch to cause simultaneous flashing of turn signal lamps when needed as a vehicular traffic hazard warning. Turn signal lamps are to be placed as wide apart as practical and their horizontal centerline shall be a maximum of 12 inches below the rear window.
2. Buses shall be equipped with amber side-mounted turn signal lights.
3. Buses shall be equipped with four combination red stop/tail lamps.
 - a. Two combination lamps with a minimum diameter of 7 inches, or if a shape other than round, a minimum 38 square inches of illuminated area shall be mounted on the rear of the bus just inside the turn signal lamps.
 - b. Two combination lamps with a minimum diameter of 4 inches, or if a shape other than round, a minimum 12 square inches of illuminated area, shall be placed on the rear of the body between the beltline and the floor line. The rear license plate lamp may be combined with one lower tail lamp. Stop lamps shall be activated by the service brakes and shall emit a steady light when illuminated.

- E. On buses equipped with a monitor for the front and rear lamps of the school bus, the monitor shall be mounted in full view of the driver. If the full circuit current passes through the monitor, each circuit shall be protected against any short

circuit or intermittent shorts by a fuse circuit breaker, or electronic protection device.

- F. An optional white flashing strobe lamp may be installed on the roof of a school bus, at a location not to exceed 1/3 the body length forward from the rear of the roof edge. The lamp shall have a single clear lens emitting light 360 degrees around its vertical axis and it may not extend above the roof more than a maximum legal height. A manual switch and a pilot lamp shall be included to indicate when lamp is in operation. Optionally, the strobe light may be mounted on the roof in the area directly over the restraining barrier on the driver's side; may be wired to activate with the amber alternately flashing signal lamps, continuing through the full loading or unloading cycle; and may be equipped with an override switch to allow activation of the strobe at any time for use in inclement weather.
- G. The bus body shall be equipped with two white rear backup lamps that are at least 4 inches in diameter or, if a shape other than round, a minimum of 12 square inches of illuminated area and shall meet FMVSS No. 108. If backup lamps are placed on the same horizontal line as the brake lamps and turn signal lamps, they shall be to the inside.
- H. A daytime running lamps (DRL) system shall be provided.

METAL TREATMENT

- A. All metal except high-grade stainless steel or aluminum used in construction of the bus body shall be zinc-coated or aluminum-coated or treated to prevent corrosion. This includes but is not limited to such items as structural members, inside and outside panels, door panels and floor sills. Excluded are such items as door handles, grab handles, interior decorative parts and other interior plated parts.
- B. All metal parts that will be painted, in addition to above requirements, shall be chemically cleaned, etched, zinc phosphate-coated and zinc chromate or epoxy-primed to improve paint adhesion. This includes, but is not limited to, such items as crossing control arm and stop arm.
- C. In providing for these requirements, particular attention shall be given to lapped surfaces, welded connections of structural members, cut edges on punched or drilled hole areas in sheet metal, closed or box sections, un-vented or un-drained areas and surfaces subjected to abrasion during vehicle operation.
- D. As evidence that the above requirements have been met, sample of materials and sections used in construction of the bus body shall be subjected to a cyclic corrosion testing as outlined in SAE JI563.

MIRRORS

- A. The interior glass mirror shall be either laminated or tempered and shall have rounded corners and protected edges. Mirrors shall be 6x16 inches minimum for Type A buses and be 6x30 inches minimum for Types of C and D buses.
- B. Each school bus shall be equipped with exterior mirrors meeting the requirements of FMVSS No. 111, *Rearview Mirrors*. The right side rear view mirror shall not be obscured by the un-wiped portion of the windshield. Mirrors shall be easily adjustable, but shall be rigidly braced so as to reduce vibration.
- C. Heated external mirrors may be used.
- D. Remote controlled external rear view mirrors may be used.

MOUNTING

- A. The rear body cross member shall be supported by the chassis frame. Except where chassis components interfere, the bus body shall be attached to the chassis frame at each main floor sill in such a manner as to prevent shifting or separation of the body from the chassis under severe operating conditions.
- B. Isolators shall be installed at all contact points between body and chassis frame on Types A-2, B, C and D buses, and shall be secured by a positive means to the chassis frame or body to prevent shifting, separation, or displacement of the isolators under severe operating conditions.

OIL FILTER

An oil filter with a replacement element shall be provided and connected by flexible oil lines if it is not a built-in or an engine-mounted design. The oil filter shall have a capacity in accordance with the engine manufacturer's recommendation.

OPENINGS

All openings in the floorboard or firewall between chassis and passenger compartment (e.g., for gearshift selector and parking brake lever) shall be sealed.

OVERALL LENGTH

Overall length of bus shall not exceed 45 feet, excluding accessories.

OVERALL WIDTH

Overall width of bus shall not exceed 102 inches, excluding accessories.

PASSENGER LOAD

- A. Actual gross vehicle weight (GVW) is the sum of the chassis weight plus the body weight, plus the driver's weight, plus total seated student weight. For the purposes of calculation, the driver's weight is 150 pounds and for the purposes of calculation, the pupil weight is 120 pounds per pupil.
- B. Actual GVW shall not exceed the chassis manufacturer's GVWR for the chassis, nor shall the actual weight carried on any axle exceed the chassis manufacturer's Gross Axle Weight Rating (GAWR).

PUBLIC ADDRESS SYSTEM

- A. Buses may be equipped with an AM/FM/audio and/or public address system having interior and exterior speakers.
- B. No internal speakers, other than driver's communication systems, may be installed within four feet of the driver's seat back in its rearmost upright position.

RETARDER SYSTEM (Optional equipment)

A retarder system, if used, shall limit the speed of the fully loaded school bus at 19.0 mph on a 7 percent grade for 3.6 miles.

RETRO-REFLECTIVE MATERIAL

(See also APPENDICES A and B, Retro-reflective Sheeting)

- A. The front and/or rear bumper may be marked diagonally 45 degrees down toward the centerline of pavement with two $\pm 1/4$ inch wide strips of non-contrasting retro-reflective material.
- B. The rear of the bus body shall be marked with strips of retro-reflective NSBY material to outline the perimeter of the back of the bus using material which conforms with the requirements of FMVSS No. 131, *School Bus Pedestrian Safety Devices*, Table 1. The perimeter marking of rear emergency exits per FMVSS No. 217, *Bus Emergency Exits and Window Retention and Release*, and/or the use of retro-reflective "SCHOOL BUS" signs partially accomplishes the objective of this requirement. To complete the perimeter marking of the back of the bus, strips of retro-reflective NSBY material, a minimum of 1 inch and a maximum of 2 inches in width shall be applied horizontally above the rear

windows and above the rear bumper, extending from the rear emergency exit perimeter, marking outward to the left and right rear corners of the bus. Vertical strips shall be applied at the corners connecting these horizontal strips.

- C. "SCHOOL BUS" signs, if not a lighted design, shall be marked with retro-reflective NSBY material comprising background for lettering of the front and/or rear "SCHOOL BUS" signs.
- D. Sides of bus body shall be marked with at least 1¾ inch retro-reflective NSBY material, extending the length of the bus body and located (vertically) between the floor line and the beltline.
- E. If used, signs placed on the rear of the bus relating to school bus flashing signal lamps or railroad stop procedures may be retro-reflective material.

ROAD SPEED CONTROL

When it is desired to accurately control vehicle maximum speed, a vehicle speed limiter may be utilized.

RUB RAILS

- A. There shall be one rub rail on each side of bus located at, or no more than 8 inches above, the seat cushion level. They shall extend from the rear side of the entrance door completely around the bus body (except at the emergency door or any maintenance access door) to point of curvature near the outside cowl on the left side.
- B. There shall be one additional rub rail on each side located 10 inches or less above the floor line. The rub rail shall cover the same longitudinal span as the upper rub rail, except at the wheel housing, and it shall extend only to the longitudinal tangent of the right and left rear corners.
- C. Rub rails above the floor line shall be attached at each body post and at all other upright structural members.
- D. Each rub rail shall be 4 inches or more in width in its finished form and shall be constructed of 16-gauge metal or other material of equivalent strength suitable to help protect body side panels from damage. Rub rails shall be constructed in corrugated or ribbed fashion.
- E. Rub rails shall be applied outside the body or outside body posts. (Pressed-in or snap-on rub rails do not satisfy this requirement.) For Type A-1 vehicles using the body provided by the chassis manufacturer or for Types A-2, B, C and D buses containing the rear luggage or rear engine compartment, rub rails need not extend around rear corners.

- F. The bottom edge of the body side skirts shall be stiffened by application of a rub rail, or the edge may be stiffened by providing a flange or other stiffeners.

SEAT AND RESTRAINING BARRIERS

A. Passenger Seating

1. School bus design capacities shall be in accordance with 49 CFR, Part 571.3, *Definitions*, and FMVSS No. 222, *School Bus Passenger Seating and Crash Protection*.
2. All seats shall have a minimum cushion depth of 15 inches, a seat back height of 24 inches above the seating reference point, and must comply with all other requirements of FMVSS No. 222.
3. All restraining barriers and passenger seats shall be constructed with materials that enable them to meet the criteria of the *School Bus Seat Upholstery Fire Block Test*.
4. Each seat leg shall be secured to the floor by a minimum of two bolts, washers, and nuts. Flange-head nuts may be used in lieu of nuts and washers. All seat frames attached to the seat rail shall be fastened with two or more bolts, washers and nuts, or with flange-head nuts. Seats may be track-mounted in conformance with FMVSS No. 222.
5. If track seating is installed, the manufacturer shall supply minimum and maximum seat spacing dimensions (applicable to the bus) which comply with FMVSS No. 222. This information shall be on a label permanently affixed to the bus.
6. All school bus bodies (including Type A) shall be equipped with restraining barriers which conform to FMVSS No. 222.
7. A flip-up seat may be installed at any side emergency door. If provided, the flip-up seat shall conform to FMVSS No. 222 and aisle clearance requirements of FMVSS No. 271, *Bus Emergency Exits and Window Retention and Release*. The flip-up seat shall be free of sharp projections on the underside of the seat bottom. The underside of the flip-up seat bottoms shall be padded or contoured to reduce the possibility of clothing being snagged. Flip-up seats shall be constructed to prevent passenger limbs from becoming entrapped between the seat back and the seat cushion when the seat is in the upright position. The seat cushion shall be designed to rise to a vertical position automatically when not occupied.

8. Lap belts shall not be installed on passenger seats in large school buses (over 10,000 pounds GVWR) except in conjunction with child safety restraint systems that comply with the requirements of FMVSS No. 213, *Child Restraint Systems*.

B. Pre-School Age Seating

Passenger seats designed to accommodate a child or infant carrier seat shall comply with FMVSS No. 225, Child Restraint Anchorage Systems. These seats shall be in compliance with NHTSA's "*Guidelines for the Safe Transportation of Pre-School Age Children in School Buses*". (See A.8, above)

C. Driver Seat

1. The driver's seat supplied by the body manufacturer shall be a high back seat. The seat back shall be adjustable to 15 degrees minimum, without requiring the use of tools. The seat shall be equipped with a head restraint to accommodate a 5th percentile female to a 95th percentile adult male, as defined in FMVSS No. 208, *Occupant Crash Protection*.
2. Type A buses may utilize the standard driver's seat provided by the chassis manufacturer.

D. Driver Restraint System

A Type 2 lap/shoulder belt shall be provided for the driver. On buses where the driver's seat and upper anchorage for the shoulder belt are both attached to the body structure, a driver's seat with an integrated Type 2 lap/shoulder belt may be substituted. On buses where the driver's seat and upper anchorage for the shoulder belt are separately attached to both body and chassis structures (i.e., one attached to the chassis and the other attached to the body), a driver's seat with an integrated Type 2 lap/shoulder belt should be used.

The assembly shall be equipped with an emergency locking retractor for the continuous belt system. On all buses except Type A that are equipped with a standard chassis manufacturers driver's seat, the lap portion of the belt system shall be guided or anchored to prevent the driver from sliding sideways under the belt system. The lap/shoulder belt shall be designed to allow for easy adjustment in order to fit properly and to effectively protect drivers varying in size from 5th percentile adult female to 95th percentile adult male.

- E. Each bus shall be equipped with a durable belt cutter having a full width handgrip and a protected, replaceable or non-corrodible blade. The required belt cutter shall be mounted in a location accessible to the seated driver in an easily detachable manner.

SHOCK ABSORBERS

The bus shall be equipped with a double-action shock absorber compatible with manufacturer's rated axle capacity at each wheel location.

SIDE SKIRTS

School bus body side skirts between the front and rear axles shall extend down to within 2 inches plus or minus, of the horizontal line from the center of the front spindle to the center of the rear axle. The manufacturer may offer optional side skirt lengths that extend lower than this requirement. This measurement shall apply to a new unloaded school bus located on a flat, level surface.

STEERING GEAR

- A. The steering gear shall be approved by the chassis manufacturer and designed to ensure safe and accurate performance when the vehicle is operated with maximum load and at maximum speed.
- B. If external adjustments are required, the steering mechanism shall be accessible to make adjustments.
- C. Changes shall not be made to the steering apparatus which are not approved by the chassis manufacturer.
- D. There shall be a clearance of at least 2 inches between the steering wheel and cowl, instrument panel, windshield, or any other surface.
- E. Power steering is required and shall be of the integral type with integral valves.
- F. The steering system shall be designed to provide a means for lubrication of all wear-points that are not permanently lubricated.

STEPS

- A. The first step at the entrance door shall be not less than 10 inches and not more than 14 inches from the ground when measured from top surface of the step to the ground, based on standard chassis specifications, except that on Type D vehicles, the first step at the entrance door shall be 12 inches to 16 inches from the ground. An auxiliary step may be provided to compensate for the increase in ground-to-first-step clearance. The auxiliary step is not required to be enclosed.
- B. Step risers shall not exceed a height of 10 inches. Exception: When plywood is used on a steel floor or step, the riser height may be increased by the thickness of the plywood.

- C. Steps shall be enclosed to prevent accumulation of ice and snow.
- D. Steps shall not protrude beyond the side body line.

STEP TREADS

- A. All steps, including floor line platform area, shall be covered with an elastomer floor covering having a minimum overall thickness of 0.187 inch.
- B. The step covering shall be permanently bonded to a durable backing material that is resistant to corrosion.
- C. Steps, including floor line platform area, shall have a 1½-inch nosing that contrasts in color by at least 70 percent measured in accordance with the contrasting color specification in 36 CFR Part 1192 ADA, *Accessibility Guidelines for Transportation Vehicles*.
- D. Step treads should have the following characteristics:
 - 1. Abrasion resistance: Step tread material weight loss shall not exceed 0.40 percent, as tested under ASTM D-4060, *Standard Test Method for Abrasion Resistance of Organic Coatings by the Taber Abraser, (CS-17 Wheel, 1000 gram, 1000 cycle)*;
 - 2. Weathering resistance: Step treads shall not break, crack, or check after ozone exposure (7 days at 50 phm at 40 degrees C) and weatherometer exposure (ASTM D-750, *Standard Test Method for Rubber Deterioration in Carbon-Arc Weathering Apparatus, 7 days*): and
 - 3. Flame resistance: Step treads shall have a calculated burn rate of .01 or less using the test methods, procedures and formulas listed in FMVSS No. 302, *Flammability of Interior Materials*.

STIRRUP STEPS

If the windshield and lamps are not easily accessible from the ground, there may be at least one folding stirrup step or recessed foothold installed on each side of the front of the body for easy accessibility for cleaning. There also may be a grab handle installed in conjunction with the step. Steps are permitted in or on the front bumper in lieu of the stirrup steps if the windshield and lamps are easily accessible for cleaning from that position.

STOP SIGNAL ARM

The stop signal arm(s) shall comply with the requirements of FMVSS No. 131, *School Bus Pedestrian Safety Devices*. MFSABs are exempt from these requirements.

STORAGE COMPARTMENT (optional)

A storage container for tools, tire chains, and/or other equipment may be located either inside or outside the passenger compartment. If inside the compartment, it shall be fastened to the floor and have a cover with a positive fastening device.

SUN SHIELD

- A. For Types B, C and D vehicles, an interior adjustable transparent sun shield, with a finished edge and dimensions not less than 6x30 inches, shall be installed in a position convenient for use by driver.
- B. On Type A buses, the sun shield (visors) shall be installed by the chassis manufacturer.

SUSPENSION SYSTEMS

- A. The capacity of springs or suspension assemblies shall be commensurate with chassis manufacturer's GVWR.
- B. Rear leaf rear springs shall be of a progressive rate or multi-stage design. Front leaf springs shall have a stationary eye at one end and shall be protected by a wrapped leaf in addition to the main leaf.

THROTTLE

The force required to operate the throttle shall not exceed 16 pounds throughout the full range of accelerator pedal travel.

TIRES and RIMS

- A. Rims and tires of the proper size and load rating commensurate with chassis manufacturer's GVWR shall be provided. The use of multi-piece rims and/or tube-type tires shall not be permitted on any school bus ordered after December 31, 1995.
- B. Dual rear tires shall be provided on Type A-2, Type B, C and D school buses.

- C. All tires on a vehicle shall be of the same size, and the load range of the tires shall meet or exceed the GVWR as required by FMVSS No. 120, *Tire Selection and Rims for Vehicles other than Passenger Car*.
- D. If the vehicle is equipped with a spare tire and rim assembly, it shall be the same size as those mounted on the vehicle.
- E. If a tire carrier is required, it shall be suitably mounted in an accessible location outside the passenger compartment.

TOWING ATTACHMENT POINTS

Front and/or rear towing devices (i.e. tow hooks, tow eyes, or other designated towing attachment points) shall be furnished to assist in the retrieval of buses that are stuck and/or for towing buses when a wrecker with a “wheel lift” or an “axle lift” is not available or cannot be applied to the towed vehicle.

- A. Towing devices shall be attached to the chassis frame either by the chassis manufacturer or in accordance with the chassis manufacturer’s specifications.
- B. Each towing device shall have a strength rating of 13,500 pounds each, for a combined rating of 27,000 pounds with the force applied in the rearward direction, parallel to the ground, and parallel to the longitudinal axis of the chassis frame rail. For pulling and lifting purposes, tow hooks are meant to be used simultaneously. For pulling, angularity applied to the tow hooks will decrease the capacities of the tow hooks.
- C. The towing devices shall be mounted such that they do not project forward of the front bumper or rearward of the rear bumper.

Note: Type A buses are exempt from this requirement for the front tow hooks or eyes due to built-in crush zones.

TRACTION ASSISTING DEVICES (Optional)

- A. Where required or used, sanders shall:
 - 1. Be of hopper cartridge-valve type;
 - 2. Have a metal hopper with all interior surfaces treated to prevent condensation of moisture;
 - 3. Be of at least 100 pound (grit) capacity;
 - 4. Have a cover that screws in place on the filler opening of hopper, thereby sealing the unit airtight;

5. Have discharge tubes extending under the fender wheel housing to the front of each rear wheel;
 6. Have no-clogging discharge tubes with slush-proof, non-freezing rubber nozzles;
 7. Be operated by an electric switch with a pilot light mounted on the instrument panel located so as to exclusively be controlled by the driver;
 8. Be equipped with a gauge to indicate that the hopper has reached the one-quarter level (and needs to be refilled); and
 9. Be designed to prevent freezing of all activation components and moving parts.
- B. Automatic traction chains may be installed.

TRANSMISSION

- A. Automatic transmissions shall have no fewer than three forward speeds and one reverse speed. Mechanical shift selectors shall provide a detent between each gear position when the gear selector quadrant and shift selector are not steering-column mounted.
- B. In manual transmissions, second gear and higher shall be synchronized, except when incompatible with engine power. A minimum of three forward speeds and one reverse speed shall be provided.
- C. Automatic transmissions incorporating a parking pawl shall have a transmission shifter interlock controlled by the application of the service brake to prohibit accidental engagement of the automatic transmission. All non-park pawl transmissions shall incorporate a park brake interlock that requires the service brake to be applied to allow release of the parking brake.

TRASH CONTAINER and HOLDING DEVICE (OPTIONAL)

When requested or used, the trash container shall be secured by a holding device that is designed to prevent movement and to allow easy removal and replacement. It shall be installed in an accessible location in the driver's compartment, not obstructing passenger access to the entrance door.

TURNING RADIUS

- A. A Chassis with a wheelbase of 264 inches or less shall have a right and left turning radius of not more than 42½ feet, curb-to-curb measurement.
- B. A chassis with a wheelbase of 265 inches or more shall have a right and left turning radius of not more than 44½ feet, curb-to-curb measurement.

UNDERCOATING

- A. The entire underside of the bus body, including floor sections, cross member and below floor-line side panels, shall be coated with rust-proofing material for which the material manufacturer has issued to the bus body manufacturer a notarized certification to the bus body manufacturer that materials meet or exceed all performance requirements of SAE J1959.
- B. The undercoating material shall be applied with suitable airless or conventional spray equipment to the undercoating material manufacturer recommended film thickness and shall show no evidence of voids in the cured film.
- C. The undercoating material shall not cover any exhaust components of the chassis.

VENTILATION

- A. Auxiliary fans (OPTIONAL) shall meet the following requirements:
 - 1. Fans for left and right sides of the windshield shall be placed in a location where they can be adjusted for maximum effectiveness and where they do not obstruct vision to any mirror. Note: All Type A buses may be equipped with one fan;
 - 2. Fans shall be a 6 inch (nominal) diameter; and
 - 3. Fan blades shall be enclosed in a protective cage. Each fan shall be controlled by a separate switch.
- B. The bus body shall be equipped with a suitably controlled ventilating system with capacity sufficient to maintain the proper quantity of air flow under operating conditions without having to open a window except in extremely warm weather.
- C. Static-type, non-closeable exhaust ventilation shall be installed in low-pressure area of roof.
- D. Roof hatches designed to provide ventilation in all types of exterior weather conditions may be provided.

WHEELHOUSING

- A. The wheelhousing opening shall allow for easy tire removal and service.
- B. Wheel housings shall be attached to floor panels in a manner to prevent any dust, water or fumes from entering the body. Wheel housings shall be constructed of 16-gauge (or thicker) steel.
- C. The inside height of the wheel housings above the floor line shall not exceed 12 inches.
- D. The wheel housings shall provide a clearance for installation and use of tire chains on single and dual (if so equipped) power-driving wheels.
- E. No part of a raised wheelhousing shall extend into the emergency door opening.

WINDOWS

- A. Other than emergency exits designated to comply with FMVSS No. 217, *Bus Emergency Exits and Window Retention and Release*, each side window shall provide an unobstructed opening of at least 9 inches high (but not more than 13 inches high) and at least 22 inches wide, obtained by lowering window. One window on each side of the bus may be less than 22 inches wide.
- B. Optional tinted and/or frost-free glazing may be installed in doors or windows.
- C. Windshields shall comply with federal, state and local regulations.

WINDSHIELD WASHERS

A windshield washer system shall be provided.

WINDSHIELD WIPERS

- A. A two-speed or variable speed windshield wiping system, with an intermittent feature, shall be provided and may be operated by a single switch.
- B. The wipers shall meet the requirements of FMVSS No. 104, *Windshield Wiping and Washing Systems*.

SPECIALLY EQUIPPED SCHOOL BUS SPECIFICATIONS

INTRODUCTION

Equipping buses to accommodate students with disabilities is dependent upon the needs of the passengers. While one bus may be fitted with a lift, another may have belts installed to secure child seats. Buses so equipped are not to be considered a separate class of school bus, but simply a regular school bus that is equipped for special accommodations.

The specifications in this section are intended to supplement specifications in the BODY AND CHASSIS section. In general, specially equipped buses shall meet all the requirements of the preceding sections, plus those listed in this section. It is recognized that the field of special transportation is characterized by varied needs for individual cases and by rapidly emerging technologies for meeting individual student needs. A flexible, “common sense” approach to the adoption and enforcement of specifications for these vehicles, therefore, is prudent.

As defined by 40 Code of Federal Regulations (CFR) § 571.3, “*Bus*” means a motor vehicle with motive power, except a trailer, designed for carrying more than ten persons” (11 or more including the driver). This definition also embraces the more specific category, *school bus*. Vehicles with ten or fewer occupant positions (including the driver) are not classified as buses. For this reason, the federal vehicle classification, *multipurpose passenger vehicle* (49 CFR § 571.3), or MPV, must be used by manufacturers for these vehicles in lieu of the classification *school bus*.

The definition of *designated seating position* in 49 CFR § 571.3 states that, in the case of “vehicles sold or introduced into interstate commerce for purposes that include carrying students to and from school or related events” and which are “intended for securement of an occupied wheelchair during vehicle operations,” each wheelchair securement position shall be counted as four designated seating positions when determining the classification (whether *school bus* or *MPV*). This classification system does not preclude state or local agencies or these national specifications from requiring compliance of school bus-type MPVs with the more stringent federal standards for school buses. The following specifications address modifications as they pertain to school buses that, with standard seating arrangements prior to modification, would accommodate eleven or more occupants including the driver. If by addition of a power lift, wheelchair positions or other modifications, the capacity is reduced as such that vehicles become MPVs, the intent of these specifications is to require these vehicles to meet the same specifications they would have had to meet prior to such modifications, and such MPVs, are included in all references to school buses and requirements for school buses which follow.

DEFINITION

A specially equipped school bus is any school bus that is designed, equipped and/or modified to accommodate students with special transportation needs.

GENERAL REQUIREMENTS

- A. Specially equipped school buses shall comply with the *National School Transportation Specifications & Procedures* and with the Federal Motor Vehicle Safety Standards (FMVSS) applicable to the Gross Vehicle Weight Rating (GVWR) category.
- B. Any school bus to be used for the transportation of children who utilize a wheelchair or other mobile positioning device, or who require life-support equipment that prohibits use of the regular service entrance, shall be equipped with a power lift, unless a ramp is needed for unusual circumstances related to passenger needs.

AISLES

All school buses equipped with a power lift shall provide a minimum 30-inch pathway leading from any wheelchair position to at least one 30" wide emergency exit door. A wheelchair securement position shall never be located directly in front of (blocking) a power lift door location.

GLAZING

Tinted glazing may be installed in all doors, windows, and windshields consistent with federal, state, and local regulations.

IDENTIFICATION

Specially equipped school buses shall display the International Symbol of Accessibility below the window line. Such emblems shall be white on blue or black background, shall not exceed 12 inches square in size and shall be of a high-intensity retro-reflective material meeting the requirements of Federal Highway Administration (FHWA) FP-85, *Standard Specifications for Construction of Roads and Bridges on Federal Highway Projects*.

PASSENGER CAPACITY RATING

In determining the passenger capacity of a school bus for purposes other than actual passenger load (e.g., vehicle classification or various billing/reimbursement models), any location in a school bus intended for securement of a wheelchair during vehicle operation

shall be regarded as four designated seating positions, and each lift shall count as four designated seating positions.

POWER LIFTS

- A. The power lift shall be located on the right side of the bus body. **Exception:** The lift may be located on the left side of the bus if, and only if, the bus is only used to deliver students to the left side of a one-way street.
- B. All specially equipped school buses shall provide a level-change mechanism or boarding device (e.g., lift or ramp), complying with paragraph B of this section or the RAMP section, with sufficient clearances to permit a wheelchair or other mobility aid user to reach a securement location.
- C. **Vehicle lift and installation**
 - 1. **General:** Vehicle lifts and installations shall comply with the requirements set forth in FMVSS 403, *Platform Lift Systems for Motor Vehicles*, and FMVSS 404, *Platform Lift Installations in Motor Vehicles*.
 - 2. **Design loads:** The design load of the lift shall be at least 800 pounds. Working parts, such as cables, pulleys, and shafts, which can be expected to wear, and upon which the lift depends for support of the load, shall have a safety factor of at least six, based on the ultimate strength of the material. Non-working parts, such as platform, frame, and attachment hardware that would not be expected to wear, shall have a safety factor of at least three, based on the ultimate strength of the material.
 - 3. **Lift capacity:** The lifting mechanism and platform shall be capable of operating effectively with a wheelchair and occupant mass of at least 800 pounds.
 - 4. **Controls:** (See 49 CFR 571.403, S6.7, *Control Systems*.)
 - 5. **Emergency operations:** (See 49 CFR 571.403, S6.9, *Backup Operation*.)
 - 6. **Power or equipment failures:** (See 49 CFR 571.403, S6.2.2, *Maximum Platform Velocity*.)
 - 7. **Platform barriers:** (See 49 CFR 571.403, S6.4.7, *Wheelchair Retention*.)
 - 8. **Platform surface:** (See 49 CFR 571.403, S6.4.2, S6.4.3, *Platform requirements*.) (See, also “*Wheelchair or Mobility Aid Envelope*” figures at the end of this subsection.)

9. **Platform gaps and entrance ramps:** (See 49 CFR 571.403, S6.4.4, *Gaps, Transitions and Openings.*)
10. **Platform deflection:** (See 49 CFR 571.403, S6.4.5, *Platform Deflection.*)
11. **Platform movement:** (See 49 CFR 571.403, S6.2.3, *Maximum Platform Acceleration.*)
12. **Boarding direction:** The lift shall permit both inboard and outboard facing of wheelchair and mobility aid users.
13. **Handrails:** (See 49 CFR 571.403, S6.4.9, *Handrails*)
14. **Circuit breaker:** A resettable circuit breaker shall be installed between the power source and the lift motor if electrical power is used. It shall be located as close to the power source as possible, but not within the passenger/driver compartment.
15. **Excessive pressure:** (See 49 CFR 571.403, S6.8, *Jacking Prevention.*)
16. **Documentation:** The following information shall be provided with each vehicle equipped with a lift:
 - (1) A phone number where information can be obtained about installation, repair, and parts. (Detailed written instructions and a part's list shall be available upon request.)
 - (2) Detailed instructions regarding use of the lift shall be readily visible when the lift door is open, including a diagram showing the proper placement and positioning of wheelchair/mobility aids on lift.
17. **Training materials:** The lift manufacturer shall make training materials available to ensure the proper use and maintenance of the lift. These may include instructional videos, classroom curriculum, system test results, or other related materials.
18. **Identification and certification:** Each lift shall be permanently and legibly marked or shall incorporate a non-removable label or tag that states that it conforms to all applicable requirements of the current *National School Transportation Specifications and Procedures*. In addition and upon request of the original titled purchaser, the lift manufacturer or an authorized representative shall provide a notarized Certificate of Conformance, either original or photocopied, which states that the lift system meets all the applicable requirements of the current *National School Transportation Specifications and Procedures*.

Note: graphic of wheelchair or mobility aid envelope (Figure 1).

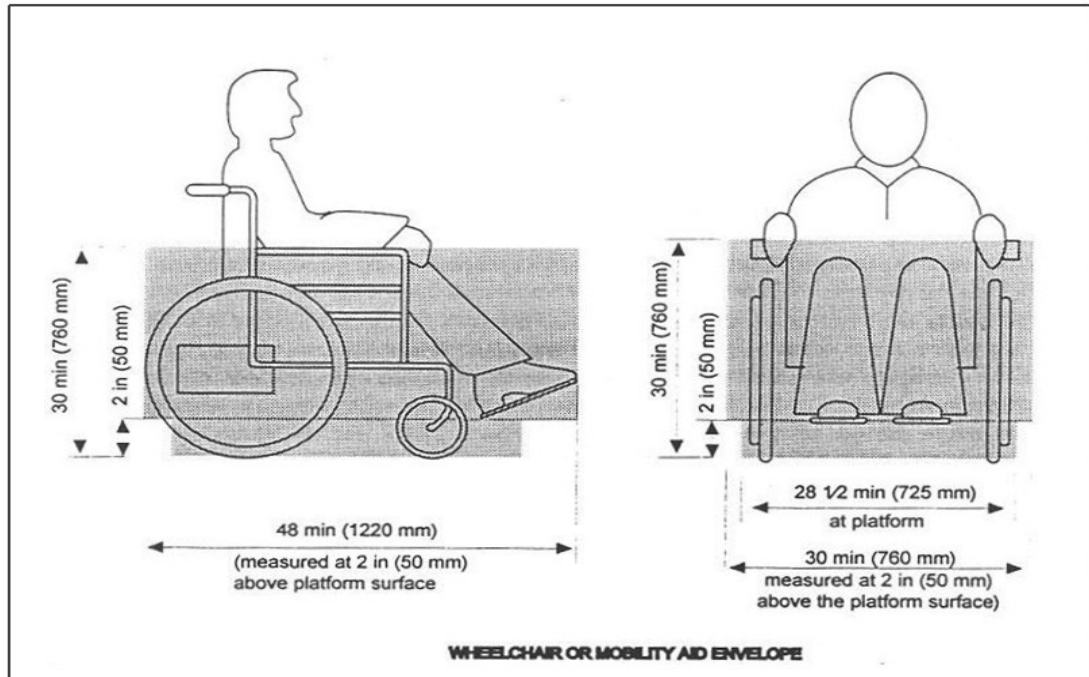

REGULAR SERVICE ENTRANCE

- A. On power lift-equipped vehicles, steps shall be the full width of the step well, excluding the thickness of the doors in the open position.
- B. In addition to the HANDRAIL required in the BUS BODY AND CHASSIS section, an additional handrail shall be provided on all SPECIALLY EQUIPPED SCHOOL BUSES. This rail shall be located on the opposite side of the entrance door from the rail required in the BUS BODY AND CHASSIS section and shall meet the same requirements for handrails.

RESTRAINING DEVICES

- A. On power-lift equipped school buses with a GVWR of 10,000 pounds or more, seat frames may be equipped with attachment points to which belt assemblies can be attached for use with child safety restraint systems (CSRS's) that comply with FMVSS No. 213, *Child Restraint Systems*. Any belt assembly anchorage shall comply with FMVSS No. 210, *Seat Belt Assembly Anchorages*.
- B. Alternatively, a child restraint anchorage system that complies with FMVSS No. 225, *Child Restraint Anchorage Systems*, may be installed.

- C. Seat belt assemblies, if installed, shall conform to FMVSS No. 209, *Child Restraint Anchorage Systems*, may be installed.
- D. Child restraint systems, which are used to facilitate the transportation of children who in other modes of transportation would be required to use a child, infant, or booster seat, shall conform to FMVSS No. 213.

SEATING ARRANGEMENTS

Flexibility in seat spacing to accommodate special devices shall be permitted to meet passenger requirements. All seating shall meet the requirements of FMVSS No. 222, *School Bus Passenger Seating and Crash Protection*.

SECUREMENT and RESTRAINT SYSTEM FOR WHEELCHAIR MOBILITY AID and OCCUPANT

For the purposes of understanding the various aspects and components of this section, the term *securement* and *tiedown* and the phrases *securement system* or *tiedown system* are used exclusively in reference to the devices that anchor the wheelchair to the vehicle. The term *restraint* or phrase *restraint systems* are used exclusively in reference to the equipment that is intended to limit the movement of the wheelchair occupant in a crash or sudden maneuver. The term *wheelchair tiedown* and *occupant restraint system (WTORS)* is used to refer to the total system that secures the wheelchair and restrains the wheelchair occupant.

A. WTORS-general requirements:

1. A wheelchair tiedown and occupant restraint system installed in specially equipped school buses shall be designed, installed, and operated for use with forward-facing wheelchair-seated passengers and shall comply with all applicable requirements of FMVSS No. 222, *School Bus Passenger Seating and Crash Protection*, and SAE J2249, *Wheelchair Tiedown and Occupant Restraint Systems for Use in Motor Vehicles*.
2. The WTORS, including the anchorage track, floor plates, pockets or other anchorages, shall be provided by the same manufacturer of all equipment/systems used.
3. Wheelchair securement positions shall be located such that wheelchairs and their occupants do not block access to the lift door.
4. A device for storage of the WTORS shall be provided. When the system is not in use, the storage device shall allow for clean storage of the system, shall keep the system securely contained within the passenger

compartment, shall provide reasonable protection from vandalism and shall enable the system to be readily accessed for use.

5. The WTORS, including the storage device, shall meet the flammability standards established in FMVSS No. 302, *Flammability of Interior Material*.
6. The following information shall be provided with each vehicle equipped with a securement and restraint system:
 - a. A phone number where information can be obtained about installation, repair and parts. (Detailed written instructions and a parts list shall be available upon request.)
 - b. Detailed instructions regarding use, including a diagram showing the proper placement of the wheelchair/mobility aids and positioning of securement devices and occupant restraints, including correct belt angles.
7. The WTORS manufacturer shall make training materials available to ensure the proper use and maintenance of the WTORS. These may include instructional videos, classroom curriculum, system test results or other related materials.
8. **Wheelchair Securement/Tiedown:** (See 49 CFT 571.403, S5.4.1, S5.4.2) Each wheelchair position in a specially equipped school bus shall have a minimum clear floor area of 30 inches laterally by 48 inches longitudinally. Additional floor area may be required for some wheelchairs. Consultation between the user and the manufacturer is recommended to ensure that adequate are is provided.
9. **Occupant restraint system:** (See 49 CFR 571.403, S5.4.3, S5.4.4)

SPECIAL LIGHT

Doorways in which lifts are installed shall be equipped with a special light that provides a minimum of two foot-candles of illumination measured on the floor of the bus immediately adjacent to the lift during operation.

SPECIAL SERVICE ENTRANCE

- A. Power lift-equipped bodies shall have a special service entrance to accommodate the power lift.
Exception: A special service entrance shall not be required if the lift is designed to operate within the regular service entrance, is capable of stowing such that the

regular service entrance is not blocked in any way and a person entering or exiting the bus is not impeded in any way.

- B. The special service entrance and door shall be located on the right side of the bus and shall be designed so as not to obstruct the regular service entrance. **Exception:** A special service entrance and door may be located on the left side of the bus only if the bus is used only to deliver students to the left side of one-way streets and its use is limited to the function.
- C. The opening may extend below the floor through the bottom of the body skirt. If such an opening is used, reinforcements shall be installed at the front and rear of the floor opening to support the floor and give the same strength as other floor openings.
- D. A drip molding shall be installed above the special service entrance to effectively divert water from entrance.
- E. Door posts and headers at the special service entrance shall be reinforced sufficiently to provide support and strength equivalent to the areas of the side of the bus not used for special service entrance.

SPECIAL SERVICE ENTRANCE DOORS

- A. A single door or double doors may be used for the special service entrance.
- B. A single door may be hinged to the forward side of the entrance unless this would obstruct the regular service entrance. If the door is hinged to the rearward side of the doorway, the door shall utilize a safety mechanism that will prevent the door from swinging open should the primary door latch fail. If double doors are used, the system shall be designed to prevent the door(s) from being blown open by the aerodynamic forces created by the forward motion of the bus, and/or shall incorporate a safety mechanism to provide secondary protection should the primary latching mechanism(s) fail.
- C. All doors shall have positive fastening devices to hold doors in the “open” position when the special service entrance is in use.
- D. All doors shall be weather sealed.
- E. When manually operated dual doors are provided, the rear door shall have at least a one-point fastening device to the header. The forward-mounted door shall have at least three one-point fastening devices. One shall be to the header, one to the floor line of the body, and the other shall be into the rear door. The door and hinge mechanism shall be of a strength that is greater than, or equivalent to, the emergency exit door.

- F. Door materials, panels and structural components shall have strength equivalent to the conventional service and emergency doors. Color, rub rail extensions, lettering and other exterior features shall match adjacent sections of the body.
- G. Each door shall have windows set in a waterproof manner that are visually similar in size and location to adjacent non-door windows. Glazing shall be of same type and tinting (if applicable) as standard fixed glass in other body locations.
- H. Door(s) shall be equipped with a device that will actuate an audible or visible signal located in the driver's compartment when door(s) is not securely closed and ignition is in "on" position.
- I. A switch shall be installed so that the lift mechanism will not operate when the lift platform door(s) is closed.
- J. Special service entrance doors shall be equipped with padding at the top edge of the door opening. The padding shall be at least 3 inches wide and 1 inch thick and shall extend the full width of the door opening.

SUPPORT EQUIPMENT and ACCESSORIES

- A. In addition to the belt cutter required in the BUS BODY AND CHASSIS section, each specially equipped school bus that is set up to accommodate wheelchairs or other assistive or restraint devices with belts attached shall contain an additional belt cutter properly secured in a location to be determined by the purchaser. The belt cutter shall meet the requirements listed in the BUS BODY AND CHASSIS section, Seats and Restraining Barriers.
- B. Special equipment or supplies that are used on the bus for mobility assistance, health support or safety purposes shall meet local, federal and engineering standards that may apply, including requirements for proper identification. Equipment that may be used for these purposes includes, but is not limited to:
 - 1. Wheelchairs and other mobile seating devices. (See subsection on Securement and Restraint System for Wheelchairs and Wheelchair-seated Occupants.)
 - 2. Crutches, walkers, canes, and other ambulating devices to assist ambulation.
 - 3. Medical support equipment. This may include respiratory devices, such as oxygen bottles (which should be no larger than 38 cubic feet for compressed gas) or ventilators. Tanks and valves should be located and positioned to protect them from direct sunlight, bus heater vents or other heat sources. Other equipment may include intravenous and fluid drainage apparatus.

TECHNOLOGY and EQUIPMENT, NEW

It is the intent of these specifications to accommodate new technologies and equipment that will better facilitate the transportation of students with special needs. New technology and equipment is acceptable for use in specially equipped vehicles if:

- A. It does not compromise the effectiveness or integrity of any major safety system. (Examples of safety systems include, but are not limited to, compartmentalization, the eight-lamp warning system, emergency exits and the approved color scheme.)
- B. It shall not diminish the safety of the bus interior.
- C. It does create additional risk to students who are boarding or exiting the bus or are in or near the school bus loading zone.
- D. It does not require undue additional activity and/or responsibility for the driver.
- E. It generally increases efficiency and/or safety of the bus, generally provides for a safer or more pleasant experience for the occupants and pedestrians in the vicinity of the bus and/or generally assists the driver and makes his/her many tasks easier to perform.

ALTERNATIVE FUELS

INTRODUCTION

This section is designed to be used as an overview of the alternative fuels being utilized for school transportation. It is not designed to replace current applicable federal, state, manufacturing or safety specifications that may exceed requirements within this section. There may be advancements in engineering and improvements in equipment fabrication methods and operation practices that differ from those specifically called for in this section. Such deviations or improvements may provide safety and may meet the intent of, and be compatible with this section. Entities wishing to purchase alternative-fuel school buses should use this section only as a starting point. More detailed specifications, including specific design and performance criteria and safety specifications, should be researched by prospective purchasers of alternative-fuel school buses.

GENERAL REQUIREMENTS

Alternative fuel school buses shall meet the following requirements:

- A. Chassis shall meet all standards previously mentioned in *BUS BODY and CHASSIS STANDARDS*.
- B. Chassis shall meet all applicable Federal Motor Vehicle Safety Standards (FMVSSs).
- C. The fuel system integrity shall meet the specified leakage performance standards when impacted by a moving contoured barrier in accordance with test conditions specified in FMVSS No. 301, *Fuel System Integrity*, or FMVSS No. 303, *Fuel System Integrity of Compressed Natural Gas Vehicles*, as applicable.
- D. Original equipment manufacturers (OEMs) and conversion systems using compressed natural gas (CNG) shall comply with National Fire Protection Association (NFPA) Specification 52A, *Compressed Natural Gas Vehicular Fuel Systems*, in effect at the time of installation. Fuel systems using liquefied petroleum gas (LPG) shall comply with the NFPA Specification 58A, *Liquefied Petroleum Gases Engine Fuel System*, in effect at the time of installation.
- E. All alternative fuel buses shall be capable of traveling not less than 200 miles with a full load, except those powered solely by electricity shall be capable of traveling not less than 80 miles.
- F. Natural gas-powered buses shall be equipped with an interior/exterior gas detection system. All natural gas-powered buses shall be equipped with an automatic or manual fire detection and suppression system.

- G. All materials and assemblies used to transfer or store alternative fuels shall be installed outside the passenger/driver compartment.
- H. All Types C and D buses using alternative fuel shall meet the same base requirements of BUS BODY and CHASSIS STANDARDS for passenger load.
- I. The total weight shall not exceed the vehicle's GVWR when loaded to rated capacity.
- J. The manufacturer supplying the alternative fuel equipment must provide the owner and operator with adequate training and certification in fueling procedures, scheduled maintenance, troubleshooting and repair of alternative fuel equipment.
- K. All fueling equipment shall be designed specifically for fueling motor vehicles and shall be certified by the manufacturer as meeting all applicable federal, state and industry standards.
- L. All on-board fuel supply containers shall meet all appropriate requirements of the American Society for Mechanical Engineering (ASME) code, DOT regulations, or applicable FMVSS and NFPA Standards.
- M. All fuel supply containers shall be securely mounted to withstand a static force of eight times their weight in any direction.
- N. All safety devices that discharge to the atmosphere shall be vented to the outside of the vehicle. The discharge line from the safety relief valve on all school buses shall be located in a manner appropriate to the characteristics of the alternative fuel. Discharge lines shall not pass through the passenger compartment.
- O. A positive, quick acting (1/4 turn) shut-off control valve shall be installed in the gaseous fuel supply line, as close as possible to the fuel supply containers. The valve controls shall be placed in a location easily operable from the exterior of the vehicle. The location of the valve controls shall be clearly marked on the exterior surface of the bus.
- P. An electrical grounding system shall be required for grounding of the fuel system during maintenance-related venting.
- Q. Bio-Diesel must conform to the specifications of ASTM 6751, *Biodiesel Standard*.
- R. High Voltage-Powered Vehicles.

Buses utilizing a high voltage propulsion system (more than 48 nominal volts) shall meet the requirements of FMVSS No. 305, *Electric Powered Vehicles: Electrolyte Spillage and Electrical Shock Protection*, except for the following:

1. The propulsion power source (batteries, fuel cells, etc.) shall be located outside the passenger compartment.
2. The propulsion power source enclosure shall be constructed to conform to the power source manufacturer's requirements and recommendations.
3. Due to the much larger size and quantities of the propulsion power sources on larger vehicles, buses over 10,000 lbs are permitted to exceed the 5.0 liter spillage constraint of Section S5.1, "Electrolyte damage from propulsion batteries."

APPENDIX A

Definitions

Access Panel: A body panel which must be moved or removed to provide access to one or more serviceable components.

Accessibility: Ability of vehicles and facilities to accommodate people with disabilities.

Adaptive device: Any item or piece of equipment used to increase, maintain, or improve functional capabilities of children with disabilities. Also known as *assistive technology device*.

Advanced EGR (A-EGR): An EGR system utilizing advanced electronic fuel management systems combined with proprietary piston bowl design and twin turbo air management systems.

Allowable Alternate Vehicle: A vehicle designed for carrying eleven or more people, including the driver, that meets all Federal Motor Vehicle Safety Standards applicable to school buses except 49 CFR 571.108 and 571.131. (See also Multifunctional School Activity Bus)

Alternately flashing signal lamps: A system of red or red and amber signal lights mounted horizontally both front and rear, intended to identify a vehicle as a school bus and to inform other users of the highway that the bus is about to stop or is stopped to load or unload children. The system of red and amber signal lamps are available in either sequential or non-sequential operation. Also known as school bus warning lamps, pupil warning lamps, eight light warning systems, alternately flashing warning bus safety light, school bus signal lamp, alternately flashing school bus warning lights.

Non-Sequential Operation: The system of red and amber signal lamps are designed so that red lamps are activated whenever the entrance doors are opened, regardless of whether the amber lamps have been activated.

Alternative fuel Vehicle (AFV): A vehicle designed to operate on an energy source other than petroleum-based gasoline or diesel fuel. Such fuels include, but are not limited to, CNG, LNG, LPG and electricity.

Bi-fuel: A vehicle designed to operate on two different fuels, but not simultaneously.

Dual Fuel: A vehicle designed to operate on a mixture of two different fuels.

Hybrid power: The use of two or more power sources to provide the motive force for the vehicle (e.g. electricity to drive the wheels with internal combustion to supplement the battery).

Anchorage point: The point of attachment of a securement system or occupant restraint to the vehicle structure.

ANPRM: Advanced Notice of Proposed Rule Making. Notice published in the *Federal Register* by a federal agency such as NHTSA, requesting information and inviting comment on a proposed change of regulation.

ANSI: American National Standards Institute, an organization which administers and coordinates the development of voluntary industry standards.

Antilock brakes: Brake systems with sensors that automatically control the degree of wheel slip during braking and relieve brake pressure on wheels that are about to lock up. Also known as *ABS*.

Aspect ratio: Percentage used to express the ratio of a tire's height to its width; also known as *tire Profile*.

Assistive device: (See *adaptive device*.)

ASTM: ASTM International (originally known as the American Society for Testing and Materials), a voluntary standards development organization and a source for technical standards for materials, products, systems and services.

Biodiesel: Vehicle fuel made from plant or animal matter and used alone or mixed with diesel fuel in engines. B100 or “neat biodiesel” refers to the pure form. Biodiesel can be mixed with petrodiesel in any proportion, but the most common form is B20, which is 20 percent biodiesel and 80 percent petrodiesel. Bio-diesel, as defined in ASTM D 6751, is registered with the US EPA as a fuel and a fuel additive under Section 211(b) of the Clean Air Act.

Body fluids cleanup kit: Package of materials including, but not limited to, latex gloves, disposal bag, and absorbent material, used to clean up spills of potentially infected bodily fluids, under OSHA's Blood Borne Pathogens regulations and Universal Precautions practices.

Booster Seat: A firm platform, used with a lap-shoulder belt, that raises the child so that the height of his thighs and shoulders are closer to those of an adult and helps route both portions of the lap-shoulder belt to fit the smaller body; also called *belt positioning booster*.

Brake: A device or mechanism used to retard and stop the speed of a moving vehicle or to prevent the movement of a stopped vehicle.

Emergency brake: A mechanism designed to stop a motor vehicle after a failure of the service brake system.

Foundation brake: An assembly of the non-rotational components of a brake including its mechanism for developing a frictional force.

Retarder: An auxiliary braking device used to reduce brake wear and/or improve braking performance.

Service brake: The primary mechanism designed to retard and stop a moving vehicle.

Parking brake: A mechanism designed to prevent the movement of a stationary motor vehicle.

Brake fade: A condition that occurs as brakes become less effective.

Bus: A motor vehicle with motive power, except a trailer, designed for carrying more than 10 persons.

Activity bus: A bus owned, leased or contracted by a school district and regularly used to transport students on field trips, athletic trips, or other curricular or extracurricular activities, but not used for to-and-from school transportation; Must meet all FMVSS for school buses.

Charter bus: A bus that is operated under a short-term contract with a school district or other sponsor who has acquired the exclusive use of the vehicle at a fixed charge to transport students to a school-related event.

DOT bus: A school bus that meets the FMCSR standards for interstate transportation set forth in 49 CFR 390.

Intercity bus: A large bus with front doors only, high-back seats and under-floor luggage storage for high-speed, long distance trips. Also known as motor coach or over-the-road coach.

Nonconforming bus: Any vehicle designed to carry more than ten passengers that is used to transport children to or from school or school-related activities which does not meet the federal standards for school buses.

Bus, School: A bus owned, leased, contracted or operated by a school or school district and regularly used to transport students to and from school or school-related activities, but not include a charter bus or transit bus. A school bus must meet all applicable FMVSSs and is readily identified by alternately flashing lamps. National School Bus Yellow paint, and the legend "School Bus" except as may be provided for the multifunction school activity bus.

Type A: A Type "A" school bus is a conversion or bus constructed utilizing cutaway front-section vehicle with a left side driver's door. This definition includes two classifications: Type A-1, with a Gross Vehicle Weight Rating (GVWR) of 14,500 pounds or less; and Type A-2, with a GVWR greater than 14,500 and less than or equal to 21,500 pounds.

Type B: A Type "B" school bus is constructed utilizing a stripped chassis. The entrance door is behind the front wheels. This definition excludes two

classifications: Type B-1, with a GVWR of 10,000 pounds or less; and Type B-2 with a GVWR greater than 10,000 pounds.

Type C: A Type “C” school bus is constructed utilizing a chassis with a hood and front fender assembly. The entrance door is behind the front wheels; also known as a *conventional school bus*. This type also includes cutaway truck chassis or truck chassis with cab with or without a left side door and a GVWR greater than 21,500 pounds.

Type D: A type “D” school bus is constructed utilizing a stripped chassis. The entrance door is ahead of the front wheels; also known as rear or front engine transit style school buses.

Multifunction School Activity Bus (MFSAF): “A school bus whose purposes do not include transporting students to and from home or school bus stops,” as defined in 40 CFR 571.3. This subcategory of school bus meets all FMVSS for school buses except the traffic control requirements (alternately flashing signal and stop arm).

Specially equipped: A school bus designed, equipped, or modified to accommodate students with special needs.

School activity bus: Any motor coach other than a school bus or transit bus used for the transportation of any students enrolled in a public or private school at, or below, the 12th grade level, to or from school-related activities.

Bus body: The portion of a bus that encloses the bus occupant space exclusive of the bumpers, the chassis frame, and any structure forward of the forward most point of the windshield mounting.

Bus yard: An area for storage and maintenance of buses.

Cam Wrap: A seat-mounted system for attaching a safety harness to a school bus seat.

Capacity: (See *seating capacity*.)

Capitol costs: Long-term costs associated with the purchase of vehicles, buildings, and property.

Captive: Refers to a non-removable attachment, part, or fitting on a securement system.

Carrier: Any public school district, any public or private educational institution providing preschool elementary or secondary education, or any person, firm or corporation under contract to such a district or institution, engaged in transporting students.

Chassis: Vehicle frame with all operating parts including engine frame, transmission, wheels and brakes.

Chassis starting interlock circuit: A device which prevents the engine of a bus from starting if any of the emergency exits are locked.

Clean diesel: A combination of improved emission controls and clearer-burning diesel fuel (see ULSD) that significantly reduces the pollutants from diesel engines. Can refer to new vehicles that meets EPA's 2007 standards or to older vehicles retrofitted with emission control technology.

COWHAT: Committee on Wheelchairs and Transportation: a group comprised of safety experts, rehabilitation engineers, clinicians, manufacturers, and other stakeholders who work under the auspices of RESNA to develop voluntary equipment standards related to providing safer transportation for wheel-chair-seated occupants of motor vehicles.

CSRS: Child Safety Restraint System. A device (other than lap or lap/shoulder seatbelts) meeting the requirements of FMBSS 213, designed for use in a motor vehicle to restrain, seat or position a child who weights 30 kg (66 lb) or less.

Crossing arm: A device attached to the front bumper of a school bus that is activated during loading and unloading and designed to force the students to walk far enough away from the front of the bus to be seen by the driver; also known as *crossing control arm*.

Curb weight: The weight of a motor vehicle with standard equipment, maximum capacity of engine fuel, oil, and coolant, and, if applicable, air conditioning and additional weight of optional engine, but without passengers.

Deadhead: Movement of a bus without passengers (e.g., from school to bus yard).

Dealer: Any person who is engaged in the sale and distribution of new motor vehicles or motor vehicle equipment primarily to purchases who, in good faith, purchase any such vehicle or equipment for purposes other than resale.

Decibel (dB): A unit used to express the relative intensity of a sound as it is heard by the human ear. The decibel measuring scale is logarithmic. Zero (0 dB) on the scale is the lowest sound level that a normal ear can detect under very quiet ("laboratory" conditions) and is referred to as the "threshold" of human hearing. On a logarithmic scale, 10 decibels are 10 times more intense, 20 decibels are 100 times more intense, and 30 decibels are 1,000 times more intense than 1 decibel.

Decibel "A-Weighted" (dBA): The scale for measuring sound in decibels that assigns weights to different frequency ranges to reduce the effects of low and high frequencies in order to simulate human hearing.

DEF (Diesel Exhaust Fluid): The reactant necessary for the functionality of the SCR system. It is prepared by dissolving solid urea to create 32.5 percent solution in water. DEF breaks down into ammonia (NH₃) and reacts with NO_x in the SCR system to produce Nitrogen (N₂) and water (H₂O).

Distributor: Any person or company primarily engaged in the sale and distribution of motor vehicles and/or motor vehicle parts for resale

DOC: Diesel oxygenation catalyst. Devices that use a chemical process to break down pollutants in the exhaust stream of diesel engines into less harmful components.

Downtime: The period when a vehicle is not in service (e.g. due to mechanical failure or scheduled maintenance.)

DPF: Diesel particulate filter. Ceramic devices that collect particulate matter in the exhaust stream of diesel engines. The high temperature of the exhaust heats the ceramic structure and allows the particles inside to break down (or oxidize) into less harmful components.

DRL: Daytime running lamps: Head lamps that operate automatically at a reduced voltage during the day to increase the vehicle's visibility; also known as *daytime running lamps*.

Dual brake system: (See *split brake system*.)

Dual fuel system: (See *alternative fuel*.)

Dynamic testing: The process of subjecting vehicle, mobility aid, or mobility aid/securement system components to a simulated crash condition.

Effective date: The date at which a regulation or standard takes effect, on or after which compliance is legally required.

EGR (Exhaust Gas Recirculation): A type of in-cylinder NO_x reducing technology that involves the re-introduction of metered quantities of cooled exhaust gas back into the cylinder as it fills with air, displacing some of the air volume and hence some of the oxygen. Replacing a proportion of this oxygen reduces the NO_x formed during combustion.

Elastomer: An elastic substance occurring naturally, as natural rubber, or produced synthetically (e.g., butyl rubber, vinyl, etc.)

Electronic voice communication system: A means by which the driver of a vehicle can communicate with a dispatcher or other person at a remote location (e.g., two-way radio, cellular phone).

Emergency roof exit: An opening in the roof of the bus meeting the requirements of FMVSS No. 217 which provides emergency egress and sometimes ventilation; also known as *roof hatch*.

EOBR: Electronic On-Board Recorders. An electronic device that collects, stores, and displays data relative to driver and vehicle performance, including such elements as location, time, speed, and distance traveled.

Ergonomics: The study of the design of equipment to reduce human fatigue and discomfort.

Ethanol: Grain alcohol, distilled from fermented organic matter and used as a vehicle fuel.

FAPE: Free Appropriate Public Education it refers to special education and related services, including transportation, provided at public expense in accordance with a child's IEP (34 CFR 300.13 and 300.121.)

FERPA: The Family Educational Rights and Privacy Act of 1974, 20 USC 1232. Requires confidentiality of student records in public schools, but allows access to necessary information regarding student disabilities and/or health needs to those who have a need to know, including school bus drivers.

Final Rule: Notice published in the *Federal Register* by a federal agency announcing a new or changed regulation.

Final stage manufacturer: A person who performs such manufacturing operations on an incomplete vehicle that it becomes a completed vehicle.

FMCSA: Federal Motor Carrier Safety Administration, an agency of the U.S. Department of Transportation; formerly the Office of Motor Carrier Highway Safety within the Federal Highway Administration.

FMCSR: Federal Motor Carrier Safety Regulations, 49 CFT 383, 390-397, and 399; motor vehicle safety and construction standards under FMCSA that apply to commercial motor vehicles and drivers transporting passengers in interstate commerce.

FMVSS: Federal Motor Vehicle Safety Standards, 49 CFT 571. Construction standards under NHTSA that apply generally to all new motor vehicles and motor vehicle equipment.

Forward control bus: A school bus in which more than half of the engine length is rearward of the foremost point of the windshield base and the steering wheel hub is in the forward quarter of the vehicle length; also known as *transit-style* or school bus Type D).

Forward-facing: Installation of a seat (fixed bus seat or secured mobile seating device) in such a way that the mobile seating device and its occupant face the front of the vehicle when secured.

Four-point tiedown: A securement system in which four strap assemblies attach to the wheelchair frame at four separate points, and anchor to the vehicle floor at four separate points.

FSS: Fire suppressant system; a fire extinguisher system installed in the engine compartment of a vehicle and activated automatically in response to a fire sensor or manually in response to an alarm.

FTA: Federal Transit Administration, part of the U.S. Department of Transportation; formerly Urban Mass Transit Administration (UMTA).

Fuel Injection: System that uses no carburetor but sprays fuel directly into the cylinders or into intake manifold.

Glazing: The glass or glass-like portion of a window.

Laminated glass: Any glazing material that consists of one or more sheets of glass and an inboard-facing surface sheet of plastic, the components being held together by intervening plies of plastic interlayer or by the self-bonding characteristic of the inboard plastic layer.

Safety glass: Glazing material constructed, treated or combined with other material so as to reduce, in comparison with ordinary glass, the likelihood of injury to persons as a result of contact with the glass, either broken or unbroken,

Storm Window: Two or more sheets of safety glazing material separated by an air space to provide insulating properties and fixed in a common frame or mounting.

Tempered glass: Glazing which consists of glass that has been tempered to meet the properties of safety glass.

GAWR: Gross Axle Weight Rating. The value specified by the manufacturer as the load-carrying capacity of a single axle system, as measured at the tire-ground interfaces.

GPS: Global Positioning System. A satellite tracking system that enables a receiver to compute the position and speed of a vehicle.

GVW: Gross Vehicle Weight. The actual weight of the fully loaded vehicle, including all cargo, fluids, passengers, and optional equipment, as measured by a scale.

GVWR: Gross Vehicle Weight Rating. The value specified by the vehicle manufacturer as the load-carrying capacity of a single vehicle as measured at the tire-ground interfaces. For school buses, NHTSA has defined in Title 49 CFR, Section 567.4(g)(3), the minimum occupant weight allowance as 120 pounds per passenger times the number of the vehicles designated seating positions and 150 pounds for the driver.

Handrail inspection tool: A device, formed by tying a half inch hex nut to a 36 inch cord, used to inspect school bus handrails and other areas for possible snagging hazards.

Hazard lamps: Lamps that flash simultaneously to the front and rear on the right and left sides of a vehicle, used to indicate caution; also known as *four way flashers*.

Head protection zone: The empty space above and in front of each school bus passenger seat which is not occupied by side wall, window, or door structure, the dimensions of which are detailed in No. FMVSS No. 222.

Headsign: A sign above the windshield of the bus which can be changed from *School Bus* to other working such as *charter*.

Highway: Any public highway, road, street, alley, parkway, or other place open to public motor vehicle travel.

Horsepower: The measurement of an engine's ability to do work. One horsepower is the ability to lift 33,000 lbs. one foot in one minute.

ICC: The former Interstate Commerce Commission, the economic regulation agency within the Department of Transportation. The agency was disbanded in 1997 as a result of economic deregulation, and most functions transferred to the Federal Highway Administration.

IDEA: The Individuals with Disabilities Education Act, passed in 1990 as P.L. 101-476, to replace the EHA. (20 USC 1400 *et. seq.*) Also the regulations at 34 CFR Parts 300 and 303.

IEP: Individualized Education Program; a written statement developed by an assessment team for each child with a defined disability, as required under IDEA.

IFSP: Individualized Family Service Plan; a written plan for providing early intervention services to an eligible child and his or her family under Part H of IDEA.

Impact test: A simulated crash condition which evaluates the ability of a vehicle or any component or device to withstand crash forces; also known as *sled test* or *crash test*.

Inclusion: Integration of a student with disabilities into a regular classroom and onto a regular school bus; also known as *mainstreaming*.

Incomplete vehicle: An assemblage consisting, as a minimum, of frame and chassis structure, power train, steering system, suspension system, and braking system (to extent that those systems are to be part of the completed vehicle) and requiring further manufacturing operations other than the addition of readily attachable components, such as mirrors and tire and rim assemblies, or minor finishing operations such as painting, to become a complete vehicle.

Incomplete vehicle manufacturer: A manufacturer of an incomplete vehicle, i.e., a person who performs the first stage of manufacture on a vehicle manufactured in two or more stages of manufacture. (See also intermediate manufacturer and final-stage manufacturer.)

Inspection: A close examination of a motor vehicle performed in accordance with local, state and/or federal requirements, by an authorized agent of the local, state or federal government.

Integrated restraint system: A system in which the occupant restraint of an individual in a wheelchair/mobility aid connects directly to, and is dependent upon, the mobility aids securement system's rear strap assemblies.

Intermediate manufacturer: A person, other than the incomplete vehicle manufacturer or the final-stage manufacturer who performs manufacturing operations on an incomplete vehicle.

International symbol of accessibility: A white emblem on blue background used to indicate that a vehicle can accommodate individuals with disabilities.

Kneeling bus: A bus on which the front or rear end is lowered to allow easier access for passengers with disabilities.

Lap belt: A Type 1 belt assembly meeting the requirements of FMVSS No. 209 and intended to limit movement of the pelvis.

Lap/shoulder belt: A Type 2 belt assembly meeting the requirements of FMVSS No. 209 and intended to limit the movement of the pelvis and upper torso.

Lap tray: An accessory for a wheelchair or other mobile seating device, to offer support and convenience for the occupant.

LATCH System: Lower Anchors and Tethers for Children system: Incorporates standardized hardware in vehicle seats including the lower anchorages and the upper tether anchorage. It is designed to allow installation of CSRS without using the vehicles seat belt system. All CSRSs sold in the US after 2002 are required to be LATCH compatible.

LED: Light Emitting Diodes. An electronic semiconductor device that emits light when an electric current passes through it. LEDs are commonly used in lamp and digital displays.

LEA: Local Education Authority

Life cycle procurement: A procurement contract based on both the initial capital cost and the cost of operation over the life of a vehicle, intended to identify the most cost-effective time to replace as asset.

Lift: (See *power lift*.)

Load factor: The ratio of passengers actually carried to the vehicle's passenger capacity.

Low-bid procurement: Competitive procedure in which the lowest bidder is awarded the contract. See also *Performance-Based procurement*.

Low-floor vehicle: A bus in which the floor and entrance are closer to the ground, for easier access by students with disabilities or pre-schoolers.

Longitudinal: Parallel to the longitudinal centerline of the vehicle, front to rear.

Manufacturer: Any person engaged in the manufacturing or assembling of motor vehicles or items of motor vehicle equipment, including any person importing motor vehicle equipment for resale.

Medical Support Equipment: Portable equipment used by students to maintain life functions, such as oxygen bottles, intravenous or fluid drainage apparatus.

Medically fragile: Refers to students who require specialized technological health care procedures for life support and/or health support.

Mirrors: The system of mirrors required to be installed on school buses in accordance with FMVSS No. 111 and applicable state laws.

Crossview: Convex mirrors mounted on the front of the school bus and designed for student detection during loading and unloading, also known as *System B mirrors* and including *elliptical, quadric-spherical, banana, or standard convex mirrors*.

Driving: Flat and convex mirrors mounted on each side of the bus designed for viewing the road along the sides to the rear while driving; also known as *rearview, double nickel, west coast, or System A mirrors*.

Mobility aid: A wheelchair, walker, crutch, cane, or other device that is used to support and help convey a person with a physical disability.

Mobile Seating Device: A mobility aid designed to support a person in the seated position.

Modesty panel: A panel located in front of a seat or row of seats to preserve the modesty of the passengers, usually supported by a stanchion and cross bar, and does not meet the performance standards of a *barrier* as defined in FMVSS No. 222. Also, a short panel which extends from the bottom of a *barrier* to or near to the floor for the purpose of reducing the draft from the entrance door-also known as *kick panel*.

Motor carrier or carrier: The registered owner, lessee, licensee or bailee of any vehicle who operates or directs the operations of any such vehicle on either a for-hire or not-for-hire basis.

MPV: Multipurpose Passenger Vehicle; any vehicle with a seating capacity of ten or fewer, including the driver, which is built on a truck chassis, or with special features for occasional off road use.

National School Bus Yellow: The color defined in the publication “National School Bus Color Standard” SBMTC-008.

Neutral safety switch: A device which prevents the bus from starting unless the transmission is in neutral gear or the clutch is depressed.

Nominal dimension: A dimension which exists in name only (e.g. 5/8 inch plywood which is actually 19/32 inch thick, but is 5/8 inch nominal thickness). The variation between the actual dimension and the nominal dimension is the result of manufacturing practices and tolerances.

NOx (Oxides of Nitrogen): A regulated diesel emission which is a collective term for gaseous emissions composed of nitrogen and oxygen.

Nominal dimension: A dimension which exists in name only (e.g. 5/8 inch plywood which is actually 19/32 inch thick, but is 5/8 inch nominal thickness). The variation between the actual dimension and the nominal dimensions is the result of manufacturing practices and tolerances.

Non-conforming bus: A vehicle smaller than a bus, designed to carry seven to ten passengers and used to transport students, that does not meet FMVSS for school buses.

NSTA: National School Transportation Association, a membership organization comprising primarily school transportation contractor companies.

NSTSP: National School Transportation Specifications and Procedures, a publication of the National Congress on School Transportation.

NTSB: National Transportation Safety Board, an independent federal agency authorized by Congress to investigate accidents and to issue safety recommendations.

Occupant: A person who occupies space inside a school bus; refers to both passenger and driver.

On-board monitoring system: Computerized tracking of driver and vehicle performance, including speed, fuel consumption, etc. (See also *EOBR*.)

Out of Service: The removal of a school bus from passenger service due to a defective condition.

Overall vehicle width: The nominal design dimension of the widest part of the vehicle, exclusive of signal lamps, marker lamps, outside rearview mirrors, flexible fender extensions, and mud flaps, determined with the doors and windows closed and the wheels in the straight-ahead position.

Overhang: The distance from the center of the rear axle to the rearmost end of the body or from the center of the front axle to the forward edge of the front bumper.

PA system: Public address system which allows the driver of a bus to communicate with persons inside and/or outside the bus through a speaker installed on the inside and/or outside of the bus; also known as *external loudspeaker*.

Parallel restraint system: A system in which the occupant restraint lap belt anchors directly to the floor track or plates, and is independent of the wheelchair/mobility aid securement system.

Particulate trap: A device on diesel buses to clean the exhaust of particulate matter. (See also *DPF*.)

Passenger: A person who rides in a school bus but does not operate it. (See also *occupant*.)

Passenger compartment: Space within the school bus interior measured from a point 30 inches ahead of the forward most passenger seating reference point (SRP) rearward to the inside surface of the rear end of the bus at the center of the rear emergency exit.

Passenger miles: The total number of miles traveled by the aggregate number of passengers on a vehicle. (Example: Two students traveling four miles would equal 8 passenger miles and five students traveling three miles would equal 15 passenger miles-totaling 23 passenger miles.)

Postural support: A seat, belt or other component used to support a child with disabilities in a desired position, but not designed or intended to provide occupant restraint in a crash; also known as *positioning device*.

Power base: A powered, wheeled platform used to mount a seating device for carrying an individual with a disability; usually characterized by smaller diameter tires.

Power cut-off switch: A device that cancels all power from the vehicle batteries.

Power lift: A mechanized platform designed to provide access to a vehicle for an occupied mobility aid/wheelchair; also known as a *wheelchair lift*.

Positive-locking: A design feature of the mobility aid securement and occupant restraint system where the attachment and anchoring hardware cannot be inadvertently released or disengaged once properly installed.

Powertrain: The group of components used to transmit engine power to the wheels; includes engine, transmission, universal joints, driveshaft, drive axles and gears; also known as *drivetrain*.

Pusher: A school bus in which the engine is mounted in the rear of the vehicle; also known as *rear-engine bus*. (See also *School Bus, Type D*.)

Pushout window: A bus window that is hinged at the top or front to enable the window to be swung upward or outward relative to the side of the bus and provide a means of emergency egress from the bus; also known as *emergency window*.

Ramp: An inclined plane for use between the ground and the floor of the vehicle to permit access by person in wheelchair/mobility aids.

Reflective: Refers to the property of materials that cause them, when they are illuminated, to reflect the light to some extent.

Remanufactured: Refers to a vehicle component that has been structurally restored.

RESNA: Rehabilitation Engineering and Assistive Technology Society of North America, an organization engaged in research and development of assistive technology for persons with disabilities.

Restraining barrier: An assembly similar to a seat back located immediately in front of a single school bus passenger seat or row of seats to provide crash protection in accordance with FMVSS No.222; also known as *barrier, crash barrier, and seat barrier*.

Restraint system: A generic term for one or more devices intended to secure and protect a passenger with or without a mobility aid in a vehicle, including lap/shoulder belts, child safety seats, safety vests, etc.

Restraint/securement system: (See *securement and restraint system*.)

Retractor, automatic-locking: A retractor that incorporates adjustment by means of a positive self-locking mechanism which is capable of withstanding restraint forces.

Retractor, emergency-locking: A retractor that incorporates adjustment by means of a locking mechanism that is activated by vehicle acceleration, webbing movement relative to the vehicle, or automatic action during an emergency, and that is capable of withstanding restraint forces.

Retroreflective: Refers to material that is designed to direct light back to its source.

RFP: Requests for proposals; an invitation to submit a contract proposal, less restrictive than an invitation to bid on a contract.

Rim: The part of the wheel on which the tire is mounted and supported.

Roof hatch: (See *emergency roof exit*.)

Running gear: The wheels, axles, springs, frames and other carrying parts of the vehicle.

SAE: Society of Automotive Engineers, the leading standards-writing organization for the automotive industry.

Safety vest/harness: A combination pelvic and upper torso child restraint system that consists primarily of flexible material, such as straps, webbing or similar material, and that does not include a rigid seating structure for the child. Can be used with a cam wrap on a school bus seat or with a tether in other vehicles.

SBMTC: School Bus Manufacturers Technical Council; formerly the School Bus Manufacturers Institute (SBMI); a membership organization within NASDPTS which serves as a technical advisor regarding school buses technology and construction.

School bus equipment: Equipment designed primarily as a system, part or component of a school bus, or any similar part or component manufactured or sold for replacement or as an accessory or addition to a school bus.

School bus traffic warning lamps: (See *Alternately Flashing Signal Lamps.*)

SCR (Selective catalyst reduction): A type of NO_x reducing technology which uses a chemical reduction (diesel exhaust fluid, or DEF) injected into the exhaust stream where it transforms into ammonia and reacts with NO_x on a catalyst, converting the NO_x to nitrogen gas and water vapor. The reducing agent needs to be periodically replenished.

Seat: A device designed and installed to provide seating accommodations.

Activity seat: A seat-designed for passenger comfort with contoured seats and backs with the result that passengers' positions are distinctly separate; characterized by fixed seat backs; may have arm rests and head rests; can be manufactured to meet FMVSS No. 222.

Bench seat: A seat designed to accommodate more than one passenger with no apparent partitioning between positions, which is characterized by fixed legs and a fixed back e.g., the standard school bus seat which meets FMVSS No.222).

Davenport seat: A bench seat that extends from side wall to side wall at the rearmost seating position in the bus; not permitted in school buses.

Flex seat: A type of bench seat equipped with lap, shoulder seat belts that can be reconfigured so that the number of seating positions on the seat can change. An example is a seat that can be reconfigured to accommodate either three smaller students or two larger students; also known as flexible seating systems or flexible occupancy seats.

Flip seat: A school bus bench seat designed so that the cushion flips up when the seat is not occupied, similar to a theater seat; used to provide aisle clearance, as required by FMVSS No. 217, when a passenger seat is located adjacent to a side emergency door.

Integrated child safety seat: A child safety seat meeting the requirements of FMVSS No. 213 which is built into and thus an integral part of a bench seat.

Jump seat: A seat designed to fold down to provide supplemental seating in a bus (e.g. in the aisle, in front of the door or along the side wall); not permitted in school buses.

Reclining seat: An activity seat with a reclining seat back; not permitted in a school bus.

Seat belt ready seat: A bench seat meeting the requirements of FMVSS No. 222, the frame of which is designed for the installation of lap belts or CSRS attachment devised under FMS 210.

Seat belt: A passenger restraint system incorporating lap belts or lap/shoulder belts and meeting the requirements of FMVSS Nos. 209 and 201.

Seating capacity: The number of designated seating positions provided in a vehicle, including the driver's position. In determining seating capacity, each wheelchair securement location shall be counted as 4 designated seating positions.

Designed seating capacity: The theoretical passenger capacity that a vehicle would have if it were constructed with the maximum number of seating positions according to standard seating plans; also known as *manufacturer's seating capacity*.

Equipped seating capacity: The number of designated seating positions provided in a new bus per manufacturer's body/seating plan.

Reduced capacity: The capacity that is achieved when one or more seats are removed from the standard design during or after manufacture of the vehicle.

Seat position: The space on a school bus bench seat designated for one student. The number of such positions per seat is determined by dividing the width of the seat by 15" and rounding to the nearest whole number, as described in FMVSS No. 222.

Seating reference point: The manufacturer's design point, with coordinates relative to the vehicle structure, which establishes the rearmost normal driving or riding position of each designated seating position and simulates the position of the pivot center of the human torso and thigh.

Securement points: Locations on the base or seat frame of the wheelchair/mobility aid where the securement system should be attached.

Securement system: The means of securing a mobile seating device to a vehicle in accordance with FMVSS No. 222, including all necessary buckles, anchors, webbing/straps, and other fasteners.

Securement and restraint system: The total system which secures and restrains both a wheelchair/mobility aid and its occupant; also known as *WTORS*.

Sensor: An electronic device installed on a school bus for the purpose of detecting animate objects in the loading zone; also known as *object detection system*.

Skid plate: Stout metal plate attached to the underside of a vehicle to protect the oil pan, transmission, step well or fuel tank from scraping on rocks, curbs and road surface.

Slack adjuster: Adjustable device connected to the brake chamber pushrod that transmits brake application force and compensates for lining wear.

Special equipped school bus: Any school bus designed, equipped or modified to accommodate students with special needs.

Split-brake system: A service brake system with two separate hydraulic circuits which, upon failure of either, retains full or partial braking ability.

Stop arm: A device in the form of a red octagon extending outward from the side of a school bus to signal that the bus has stopped to load or unload passengers and meeting FMVSS No. 131; also known as *stop semaphore* and *stop signal arm*.

Stopping distance: Braking distance plus reaction distance.

Braking distance: The distance a vehicle travels between the time the brakes are applied and the time forward motion ceases.

Reaction distance: Distance a vehicle travels during the time it takes for a driver to recognize the need to stop and to apply the brakes.

Strobe light: A bright short duration light that flashes as a result of an electronic discharge of electricity through a gas.

Suspension system: The components of the vehicle that transmit the load of the vehicle's weight from the chassis framework to the ground, including the springs, axles, wheels, tires, and related connecting components.

Temperature control system: The means of heating or cooling the interior of the vehicle.

Tether: An upper anchor strap used in addition to a seat belt to hold certain types of restraint devices in place.

Tie-down systems: (See *securement system*.)

Tire: The continuous solid or pneumatic rubber elastomeric cushion encircling a wheel intended for contact with the road.

Bias ply: A pneumatic tire in which the ply cords extending to the beads are laid at alternate angles substantially less than 90 degrees to the centerline of the tire.

Low profile: A tire that has a section height that is less than 85 percent of its nominal section width (e.g., a tire with an aspect ratio of less than 0.85).

Radial: A pneumatic tire in which the ply cords which extend to the beads are laid substantially at 90 degrees to the centerline of the tread.

Retread: A worn tire casing to which tread rubber has been affixed to extend the usable life of the tire; also known as *re-capped* or *retreaded tire*.

Siped: A tire which has been scored or cut perpendicular to the direction of rotation (across the tread) to improve traction.

Snow: A tire with an obvious aggressive or lug type tread across the entire width which is designed to be self-cleaning.

Studded: A tire to which metal protrusions have been added to improve traction.

Tire cords: The strands forming the reinforcement structure in a tire.

Tow devices: Attachments on the chassis frame for use in retrieving a stuck vehicle and/or for towing the vehicle backwards or forwards; also known as *tow eyes*, *tow hoods* or *towing attachment points*.

Track seating: A seating system in which seating units, including mobility aids, are secured to the vehicle structure by attaching them to tracks on the vehicle floor.

Transverse: Perpendicular to the longitudinal centerline of the vehicle (i.e. from side to side).

Turbocharger: A device which uses the pressure of exhaust gases to drive a turbine that, in turn, pressurizes air normally drawn into the engine's chambers.

Turnkey: Partial privatization in which a school district hires a company to supply drivers, maintenance management, and/or vehicles; also known as *management contract*.

Two-way radio: Electronic communication system which uses a designated airway for transmission between a bus and a base station.

UCRA: Universal Child Restraint Anchorage-a standardized means of installing child restraint systems in vehicles that is independent of the seat belt system and does not include an upper tether anchorage. UCRA's have been required in all new motor vehicles under 10,000 pounds, including school buses, since September 2002.

ULSD: Ultra-low sulfur diesel. Diesel fuel that has a sulfur content of not more than 15 ppm (parts per million). Regular diesel fuel has a sulfur content of 200 ppm.

Unloaded vehicle weight: The weight of vehicle with a maximum capacity of all fluids necessary for operation, but without cargo or occupants or accessories that are ordinarily removed from the vehicle when they are not in use.

Universal precautions: Method of infection control designed to protect the individual from exposure to disease, which requires that all bodily fluids and secretions are treated as though they were infectious.

Vaporlock: Boiling or vaporization of fuel in the lines from excessive heat, which interferes with liquid fuel movement and in some cases stops the flow.

Vehicle miles: The aggregate number of miles a vehicle travels in any given period.

Video system: A means of monitoring student behavior in a school bus. The system includes one or more video cameras to tape activity. Camera housing units mounted in each bus appear to hold a camera, whether or not one is actually in place; also known as *surveillance*.

VIN: Vehicle Identification Number; a series of Arabic numbers and Roman letters which is assigned to a motor vehicle for identification purposes.

Viscosity: A measure of internal resistance to flow or motion offered by a fluid lubricant.

WC-19: A voluntary industry standard that establishes minimum design and performance requirements for wheelchairs that are occupied by users traveling in motor vehicles. The standard applies to a wide range of wheelchair types and styles, including manual wheelchairs, powerbase wheelchairs, three-wheeled scooters, tilt-in-space wheelchairs, and specialized mobile seating bases with removable seating inserts.

Weight distribution: The distribution proportion of the vehicle load divided between the front and rear axles.

Wheel: A rotating load-carrying member between the tire and the hub, usually consisting of two major parts, the rim and the wheel disc, which may be integral, permanently attached or detachable.

Ball seat nut mounting: A wheel mounting system wherein the wheel centering is provided by the wheel mounting studs and the ball seat nuts which, when properly tightened, assure the centering alignment of the wheel.

Disc: The part of the wheel which is the supporting member between the hub and the rim.

Disc Wheel: A permanent combination of a rim and wheel disc.

Hub: The rotating outer member of the axle assembly which provides for wheel disc mounting.

Locking ring: A removable, split rim ring that holds the rim flange in place on a multi-piece rim.

Piloted hub mounting: A wheel mounting system wherein the wheel centering is provided by a close fit between the wheel disc and the hub.

Rim: The part of the wheel on which the tire is mounted and supported.

Spoke wheel: A rotating member which provides for mounting and support of one or two demountable rims; also known as *wheel for demountable rim*.

Wheelbase: The distance between the centerline of the front axle and the centerline of the rear axle.

Wheelchair: A seating system comprising at least a frame, seat, and wheels, for the support and mobility of a person with physical disabilities; also known as *mobile seating device*.

Wheelchair lift: (See *power lift*.)

APPENDIX B

School Bus Chassis and Body

NATIONAL SCHOOL BUS YELLOW

The color known as National School Bus Yellow (NSBY) is specified and described in the School Bus Manufacturers Technical Council publication SBMTC-008, *National School Bus Yellow Color Standard*.

Note: Information concerning the purchase of this standard may be obtained from the Executive Director of the National Association of State Directors of Pupil Transportation Services (NASDPTS) at 1-800-585-0340, or send an email to execdir@nasdpts.org.

BUS BODY HEATING SYSTEM TEST

1. Scope

This procedure, limited to liquid coolant systems, establishes uniform cold weather bus vehicle heating system test procedures for all vehicles designed to transport ten (10) or more passengers. Required test equipment, facilities and definitions are included. Defrosting and defogging procedures and requirements are established by SAE J381, *Windshield Defrosting Systems Test Procedure and Performance Requirements—Trucks, Buses, and Multipurpose Vehicles*, and SAE J382, *Windshield Defrosting Systems Performance Guidelines—Trucks, Buses, and Multi-Purpose Vehicles*, which are hereby included by reference.

1.1 Purpose

This procedure is designed to provide bus manufacturers with a cost-effective, standardized test method to provide relative approximations of cold weather interior temperatures.

2. Definitions

2.1 Heat Exchanger System - Means will exist for providing heating and windshield defrosting, and defogging, capability in a bus. The system shall consist of an integral assembly, or assemblies, having a core assembly or assemblies, blower(s), fan(s), and necessary duct systems and controls to provide heating, defrosting and defogging functions. If the bus body structure makes up some portion of the duct system, this structure or a simulation of this structure must be included as part of the system.

- 2.2 **Heat Exchanger Core Assembly** - The core shall consist of a liquid-to-air heat transfer surface(s), liquid inlet and discharge tubes or pipes.
- 2.3 **Heat Exchanger-Defroster Blower** - An air moving device(s) compatible with energies available on the bus body.
- 2.4 **Coolant** - A 50-50 solution of commercially available glycol antifreeze and commercial purity water. Commercial purity water is defined as “that obtained from a municipal water supply system.”
- 2.5 **Heat Exchanger-Defroster Duct System** - Passages that conduct inlet and discharge air throughout the heater system. The discharge outlet louvers shall be included as part of the system.
- 2.6 **Heater Test Vehicle** - The completed bus as designed by the manufacturer with or without a chassis, engine and driver train, including the defined heat exchanger system. If the vehicle is without a chassis, it shall be placed on the test site in such a way that the finished floor of the body is at a height, from the test site floor, equal to its installed height when on a chassis, and all holes and other openings normally filled when installed on a chassis will be plugged.
- 2.7 **Heat Transfer** - The transfer of heat from liquid to air is directly proportional to the difference between the temperatures of the liquid and air entering the transfer system, for a given rate of liquid and air flow measured in pounds per minute, and that heat removed from liquid is equal to heat given to air.

3. Equipment

- 3.1 **Test Site** - A suitable location capable of maintaining an average ambient temperature not to exceed 25°F (-3.9°C) for the duration of the test period. The maximum air velocity across the vehicle shall be 5 mph (8 kph).
- 3.2 **Coolant Supply** - A closed loop system, independent of any engine/drive train system, capable of delivering a 50-50 (by volume) solution of antifreeze-water, as defined in 2.4, at $150^{\circ}\pm 5^{\circ}$ ($65.5^{\circ}\pm 1.7^{\circ}\text{C}$) above the test site ambient temperature, and 50 lbs (22.7 kg) per minute flow. The coolant supply device shall be equipped with an outlet diverter valve to circulate coolant within the device during its warm-up period. The valve will then permit switching the coolant supply to the bus heat exchanger system at the start of the test.
- 3.3 **Power Equipment Supply** - A source capable of providing the required test voltage and current for the heater system.
- 3.4 **Heat Exchange Units** - The heat exchangers used shall be labeled as specified by the School Bus Manufacturers Technical Council Standard No. 001, *Procedure for Testing and Rating Automotive Bus Hot Water and Heating and Ventilating*

Equipment (Revised 4/94). The test rating of each unit, and quantity used, shall be recorded.

4. Instrumentation

4.1 Air Temperature

4.1.1 Interior - Recommended air temperature measuring instrumentation are thermocouples or resistance temperature detectors (RTDs). Thermometers are not recommended because of their slow response to rapid temperature changes. Measuring instrumentation shall be placed on alternate seat rows beginning 39±5 inches (99±13 cm) from the rear of the body, at 36±2 inches (91±5 cm) from the finished floor of the body, and on the longitudinal centerline of the body.

4.1.2 Ambient - A set of four electrically averaged temperature measuring devices shall be placed 18±5 inches (46±13 cm) from the nearest body surface, 96±5 inches (243±13 cm) above the floor of test site. One measuring device shall be placed at each of the following locations:

- 1) Midline of body forward of windshield;
- 2) Midline of body aft of the rear surface; and
- 3) Midway between the axles on the right and left sides of the body.

4.1.3 Driver - Measuring devices shall be placed at appropriate locations to measure ankle, knee, and breath level temperatures with the driver's seat in rearmost, lowest and body center-most position.

(1) Ankle Level - Place a minimum of four electrically averaged temperature measuring devices at the corners of a 10x10 inches (25x25cm) square area, the rearmost edge of which begins 8 inches (20 cm) forward of the front edge of, and centered on, the seat cushion. The devices shall be located 3±0.5 inches (7.5±1.3 cm) above floor surface.

(2) Knee Level - Place a minimum of one measuring device at the height of the front top edge of the seat cushion and on the centerline of the seat. This measurement shall be 4±1 inches (10±2.5 cm) forward of the extreme front edge of the seat cushion and parallel to the floor.

(3) Breath Level - Place a minimum of one measuring device 42±2 inches (107±5 cm) above the floor and 10±2 inches (25±5 cm) forward of the seat back. The forward dimension shall be measured from the upper edge of the seat back and parallel to the floor.

4.1.4 (Optional) Heat Exchanger Inlet and Outlet Temperature - A minimum of four electrically averaged temperature measuring devices shall be used to measure the inlet air temperature of each heat exchange unit. Additionally, a minimum of four electronically averaged temperature measuring devices shall be used to measure the outlet air temperature of each heat exchange unit. These sensors shall be placed no closer than 2.0 inches (5.1 cm) from the face of any

heater core, to prevent any incidence of radiant heat transfer. Outlet sensors shall be distributed throughout the outlet air stream(s) 1.0 ± 0.25 inches (2.5 ± 0.6 cm) from the outlet aperture(s) of the unit heater.

4.1.5 (Optional) Defrost Air Temperature - The temperature of the defrost air shall be measured at a point in the defroster outlet(s) that is in the main air flow and which is at least 1.0 inch (2.54 cm) below (upstream of) the plane of the defroster outlet opening. At least one temperature measurement shall be made in each outlet unit. The interior surface temperature(s) of the windshield shall be measured at a point located on the vertical and horizontal centerline(s) of the windshield.

4.1.6 (Optional) Entrance Area Temperature - The temperature of the vehicle entrance area shall be measured by two sets of three each electrically averaged temperature measuring devices. One set of three devices shall be placed 1.0 inch (2.54 cm) above the lowest tread of the entrance step, equally spaced on the longitudinal centerline of the tread. The second set of devices shall be placed on the next horizontal surface above the lowest entrance step, 4.0 inches (10.2 cm) from the outboard edge of that surface, spaced identically to the first set of sensors, and placed parallel with the outboard edge of the surface being measured.

4.2 Coolant Temperature - The temperature entering and leaving the heat exchanger/defroster system shall be measured as close to the entrance and exit points of the bus body as possible with an immersion thermocouple or RTD device which can be read within $\pm 0.5^{\circ}\text{F}$ ($\pm 0.3^{\circ}\text{C}$).

4.3 Coolant Flow - The quantity of coolant flowing shall be measured by means of a calibrated flow meter or weighing tank to an accuracy of at least 2% of setpoint.

4.4 Coolant Pressure - The coolant differential pressure shall be measured by suitable connection as close as possible to the inlet and outlet of the heat exchanger/defrosting system. Pressure may be read as inlet and outlet pressure and the differential calculated, or read directly as PSID. Pressure readings shall be made with the use of gauges, manometers or transducers capable of reading within ± 0.1 psi (689.5 Pa), accurate to $\pm 0.5\%$ of full scale.

4.5 Additional Instrumentation - Additional instrumentation required for vehicle heat exchanger system testing is a voltmeter and a shunt-type ammeter to read the voltage and current of the complete system. The ammeter and voltmeter shall be capable of an accuracy of $\pm 1\%$ of the reading.

5. Test Procedures - Install the heater test vehicle on the test site. Testing shall be conducted in such a way as to prevent the effects of solar heating. At an outdoor test site, testing shall commence and data shall be recorded during the hours following sunset and prior to sunrise, regardless of cloud cover or facility roof. Instrumentation is required to obtain the following readings:

- (a) Vehicle interior (4.1.1)
- (b) Inlet coolant temperature, at entrance to the bus body (4.2)
- (c) Discharge coolant temperature, at exit from the bus body (4.2)
- (d) Voltage and current at main bus bar connection of driver's control panel.
- (e) Ambient temperature (4.1.2)
- (f) Rate of coolant flow (4.3)
- (g) Coolant flow pressure (4.4)
- (h) Elapsed time (stop watch)
- (i) Driver's station temperatures (4.1.3)
- (j) (Optional) Heat Exchanger Inlet and Outlet Temperatures (4.1.4)
- (k) (Optional) Defrost Air Temperature (4.1.5)
- (l) (Optional) Entrance Area Temperature (4.1.6)

Soak the test vehicle, with doors open, for the length of time necessary to stabilize the interior temperature for a 30 minute period as recorded by the vehicle interior temperature measuring devices, and the coolant temperature as measured by the inlet and outlet coolant temperature measuring devices, at the test site temperature, $\pm 5^{\circ}\text{F}$ ($\pm 2.5^{\circ}\text{C}$), not to exceed 25°F (-3.9°C). Warm up the coolant device to the test temperature immediately prior to the start of the test. Use the coolant supply outlet diverter valve to prevent heated coolant from entering the bus heating system prior to the start of the test. At this time, set the heater controls and all fan controls at maximum, close all doors. A maximum of two windows may be left open a total of 1.0 inch (2.5 cm) each. A maximum of two occupants may be in the body during the test period. Record all instrumentation readings at five minute intervals for a period of 1 hour. Recording time shall begin with the initial introduction of heated coolant from the independent coolant supply. The electrical system shall be operated at a maximum of 115% of nominal system voltage ± 0.2 volts, for example: 13.8 VDC ± 0.2 volts for a 12 volt (DC) system, and the heat exchanger system shall be wired with the normal vehicle wiring.

Optional - Additional flow rates and/or coolant temperatures may also be used to generate supplementary data. Procedure shall be repeated (See 5. Test Procedure.) for each additional flow rate and/or coolant temperature.

6. Computations

6.1 Chart and Computations - Customary Units-Data shall be recorded on Chart 6.1, or equivalent. Temperature data shall be recorded at the actual temperatures occurring at the time of testing. Air temperature data shall then be adjusted to a 0°F base prior to the construction of graphs. This data reduction shall be directly proportional to the difference between the actual ambient temperature, at the time of test, and 0°F (i.e., actual ambient of 18°F shall result in a reduction of all air temperatures by 18°F and actual ambient temperature of -8°F shall result in an increase of all air temperatures by 8°F). Temperature data shall be presented in graph form as well as tabular form. One graph shall be constructed for the body

interior air temperatures (4.1.1) wherein the recording intervals shall be the X-axis and the °F the Y-axis. A separate graph shall be constructed for the driver's temperatures (4.1.3) using the same units for the axes. Optional temperature data (4.1.4, 4.1.5, 4.1.6) may be similarly graphed separate from the interior data.

6.1.1 Optional Computations BTU/Hr. Coolant

Heat Transfer: $Q_w = C_p W_w (T_{in} - T_{out}) \times 60$ where:

1. $W_w =$ Flow of Coolant (lb/min) — *measured to ± 2 percent.*
2. $T_{in} =$ Temperature of Coolant into System (°F) — *measured quantity.*
3. $T_{out} =$ Temperature of Coolant out of System (°F) — *measured quantity.*
4. $Q_w =$ Heat removed From Coolant (Btu/hr) — *calculated quantity.*
5. $C_p =$ Specific Heat of Coolant = 0.8515 (BTU/lb/°F) — *given quantity.*

6.2 Chart and Computations - Metric Units - Data shall be recorded on Chart 6.2, or equivalent. Temperature data shall be recorded at the actual temperatures occurring at the time of testing. Air temperature data shall then be adjusted to a -18°C base prior to the construction of graphs. This data reduction shall be directly proportional to the difference between the actual ambient temperature, at the time of test, and -18°C (i.e., actual ambient of -7.8°C shall result in a reduction of all air temperatures by 10.2°C and actual ambient temperature of -22.2°C shall result in an increase of all air temperatures by 4.2°C). Temperature data shall be presented in graph form as well as tabular form. One graph shall be constructed for the body interior air temperatures (4.1.1) wherein the recording intervals shall be the X-axis and °C the Y-axis. A separate graph shall be constructed for the driver's temperatures (4.1.3) using the same units for the axes. Optional temperature data (4.1.4, 4.1.5, 4.1.6) may be similarly graphed separate from the interior data.

6.2.1 Optional Computations BTU/Hr – Coolant

Heat Transfer: $Q_w = C_p W_w (T_{in} - T_{out}) \times 60$ where:

1. $W_w =$ Flow of Coolant (kg/min) — *measured to ± 2 percent.*
2. $T_{in} =$ Temperature of Coolant into System (°C) — *measured quantity.*
3. $T_{out} =$ Temperature of Coolant out of System (°C) — *measured quantity.*
4. $Q_w =$ Heat removed From Coolant (Joules/hr) — *calculated quantity.*
5. $C_p =$ Specific Heat of Coolant = 3559 (joule/kg/°C) — *given quantity.*

PLACEMENT OF RETROREFLECTIVE MARKINGS AND WHITE ROOF

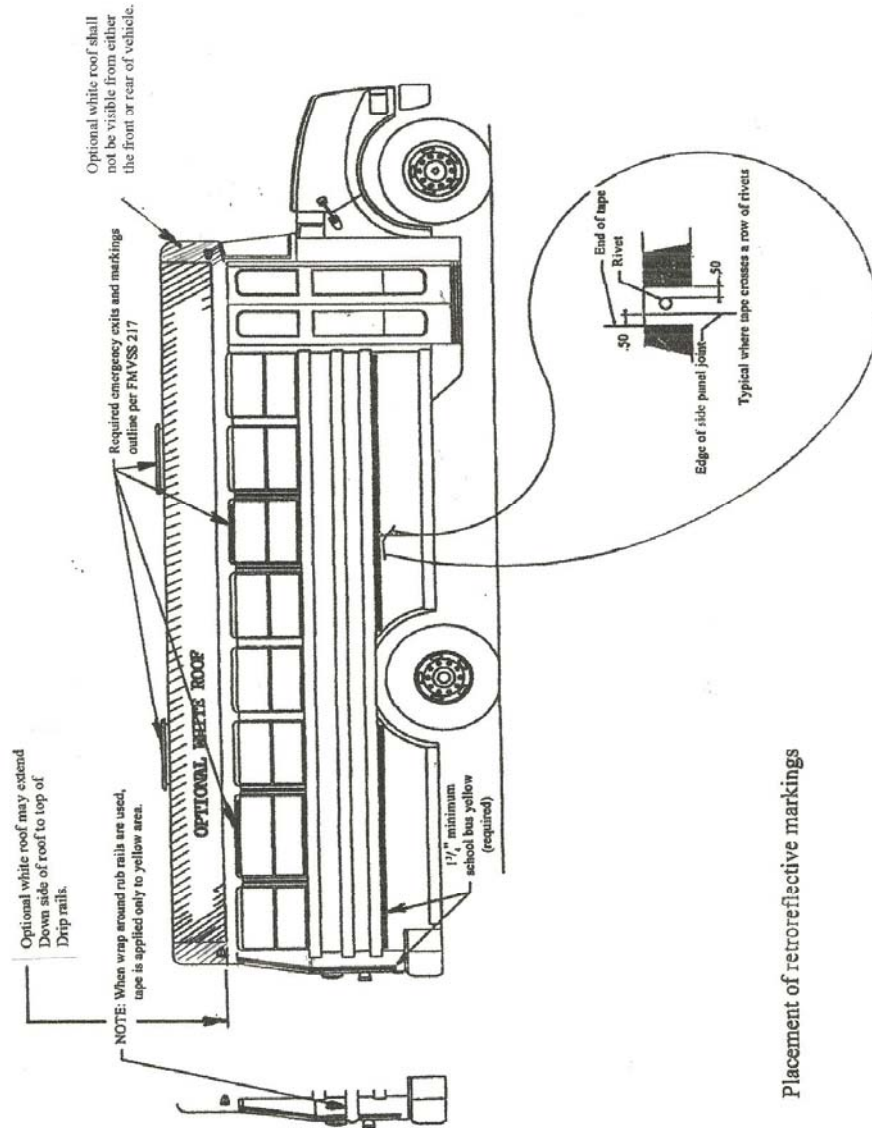

Placement of retroreflective markings

PLACEMENT OF RETROREFLECTIVE MARKINGS

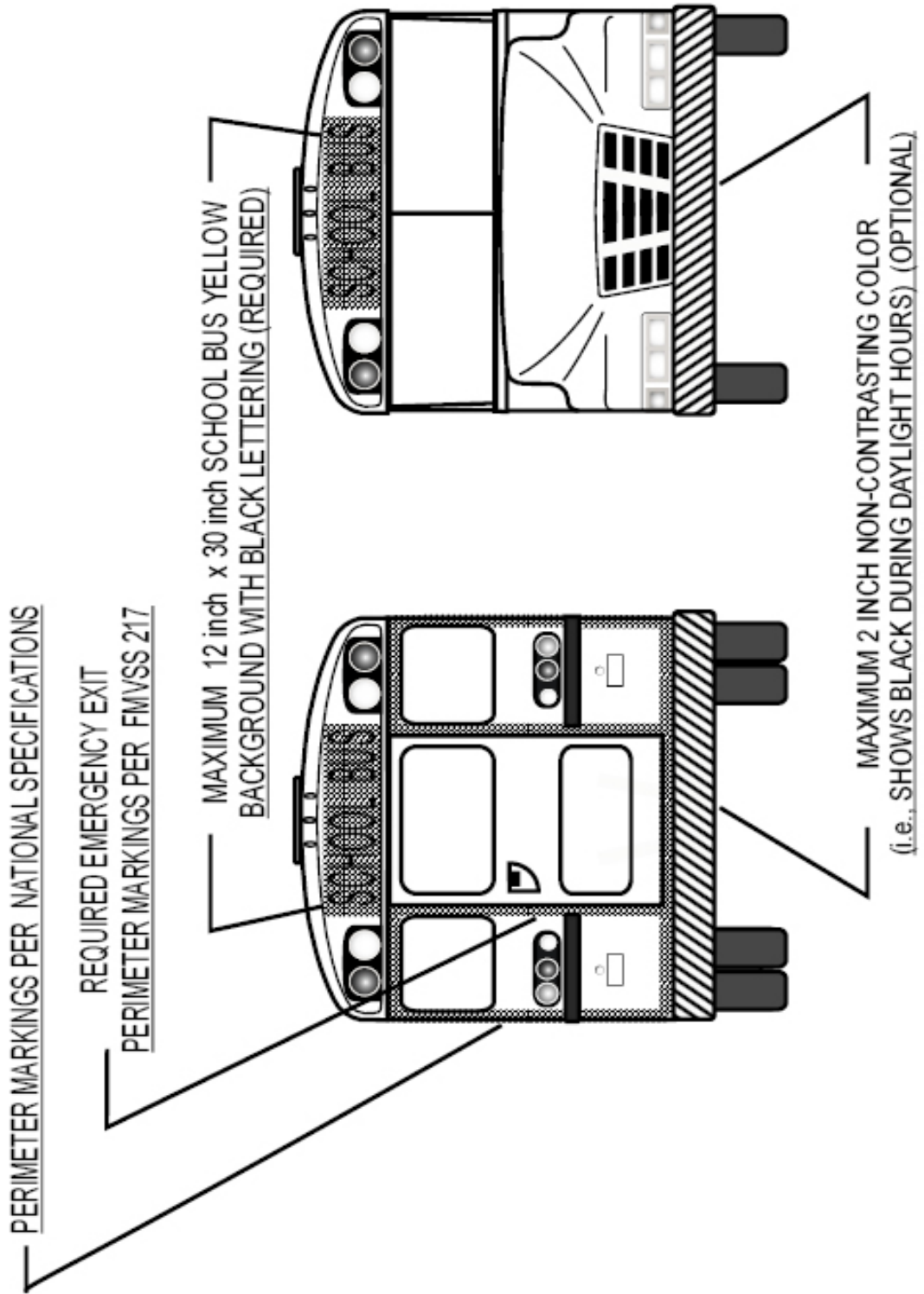

NOISE TEST PROCEDURE

- A. The vehicle is located so that no other vehicle or signboard, building, hill or other large reflecting surface is within 15.2 m (50 feet) of the occupant's seating position.
- B. All vehicle doors, windows and ventilators are closed.
- C. All power-operated accessories are turned off.
- D. The driver is in the normal seated driving position and the person conducting the test is the only other person in the vehicle.
- E. A sound level meter is used that is set at the "A-weighting fast" meter response and meets the requirements of:
 - 1. The American National Standards Institute, Standard ANSI S1.4-1971: Specifications for Sound Level Meters, for Type 1 Meters; or
 - 2. The International Electrotechnical Commission (IEC), Publication No. 179 (1973): Precision Sound Level Meters.
- F. The microphone is located so that it points vertically upward 6 inches to the right and directly in line with, and on the same plane as, the occupant's ear, adjacent to the primary noise source.
- G. If the motor vehicle's engine radiator fan drive is equipped with a clutch or similar device that automatically either reduces the rotational speed of the fan or completely disengages the fan from its power source in response to reduced engine cooling loads, the vehicle may be parked before testing with its engine running at high idle or any other speed the operator chooses for sufficient time, but not more than 10 minutes, to permit the engine radiator fan to automatically disengage.
- H. With the vehicle's transmission in neutral gear, the engine is accelerated to:
 - 1. Its maximum governed speed, if it is equipped with an engine governor; or
 - 2. Its speed at its maximum rated horsepower, if it is not equipped with an engine governor, and the engine is stabilized at that speed.
- I. The A-weighted sound level reading on the sound level meter for the stabilized engine speed condition referred to in H.1. or H.2., above, is observed and, if it has not been influenced by extraneous noise sources, is recorded.

- J. The vehicle's engine speed is returned to idle and the procedures set out in paragraphs H. and I. are repeated until 2 maximum sound levels within 2 dBA of each other are recorded. The 2 maximum sound level readings are then averaged; and
- K. The average obtained in accordance with paragraph J., with a value of 2 dBA subtracted there from to allow for variations in the test conditions and in the capabilities of meters, is the vehicle's interior sound level at the driver's seating position for the purposes of determining compliance with the requirements of this test procedure.

RETROREFLECTIVE SHEETING-DAYTIME COLOR SPECIFICATION

The daytime color of the RETROREFLECTIVE sheeting used to enhance school bus safety requires different color tolerances in order to assure optimum safety benefit, as well as to be consistent with the color of the school bus. The color of the RETROREFLECTIVE sheeting shall conform to the table below when samples applied to aluminum test panels are measured as specified in ASTM E1164. For colorimetric measurements, material is illuminated by Standard Illuminant D65 at an angle of 45 degrees with the normal to the surface the observations are made in the direction of the normal (45/0 degree geometry). The inverse (0/45 degree geometry) with the illuminant at the normal to the surface and the observations at 45 degrees with the normal to the surface may also be used. For materials which are directionally sensitive (e.g., prismatic sheeting), the colorimetric measurements are made using circumferential illumination and viewing and the various measurements are averaged. Calculations shall be done in accordance with ASTM E308 using the CIE 1931 (2 degree) Standard Observer.

Retroreflective Sheeting Daytime Color					
Chromaticity Coordinates of Corner Points					
Determining the Permitted Color Area					
	1	2	3	4	
Yellow	X	0.484	0.513	0.517	0.544
	Y	0.455	0.426	0.482	0.455
Luminance Factor (Y%)		Minimum		10.0	
		Maximum		36.0	

SCHOOL BUS SEAT UPHOLSTERY FIRE BLOCK TEST

A. Test Chamber

Cross Section

The suggested test chamber is the same cross section as the bus body in which seats are used with the rear section on each end. If a bus section is not used, the cross section is to be 91±1 inch in width x 75 inches ±3 inches in height. There shall be a door, which does not provide ventilation, in the center of each end of the test chamber. The doors shall be 38±3 inches in width and 53±3 inches in height and include a latch to keep the doors closed during the test. (See Figure 1.)

Length

The length of the test chamber shall allow three rows of seats at the minimum spacing recommended by the installer. (See Figure 1, Detail A.)

In order that different types of seats may be tested in the same chamber, a length tolerance of plus 45 inches is allowed.

Ventilation

One ventilation opening shall be in each end of the test chamber and shall be 325 square inches ±25 square inches. The bottom of the opening shall be 30 inches ±3 inches above the chamber floor. Ventilation openings shall be on the same side of the test chamber. (See Figure 1.)

There shall be no ventilation openings along the length of the test chamber.

A forced-air ventilation system may not be used.

Baffles shall be used to prevent wind from blowing directly into the ventilation openings.

CAMERA VIEW AREA

An opening covered with glass shall be provided at the midpoint of the test chamber length for camera viewing. The opening shall allow the camera to view the seat parallel to the seat width. (See Figure 1.)

A. Test Sample

The sample shall be a fully-assembled seat.

Record the weight of all padding and upholstery prior to assembly. Record the weight of the fully-assembled seat.

B. Ignition Source

A paper grocery bag with dimensions of approximately 7x11x18 inches is used to contain double sheets of newsprint (black print only, approximately 22x28inches).

The total combined weight of bag and newspaper shall be seven ounces ± 0.5 ounces.

10. Test Procedure

- 1. Install three seats in the test chamber at minimum spacing, per installer recommendation. Seats shall be perpendicular to the dimension indicated as “length” in Figure 1. Install so that seat frames will not fall during the test. Seat width shall be determined so that maximum passenger capacity per row (two seats) for the seat style shall be tested.

- 2. For each test, position the ignition source in the following positions outlined.

Figure 1

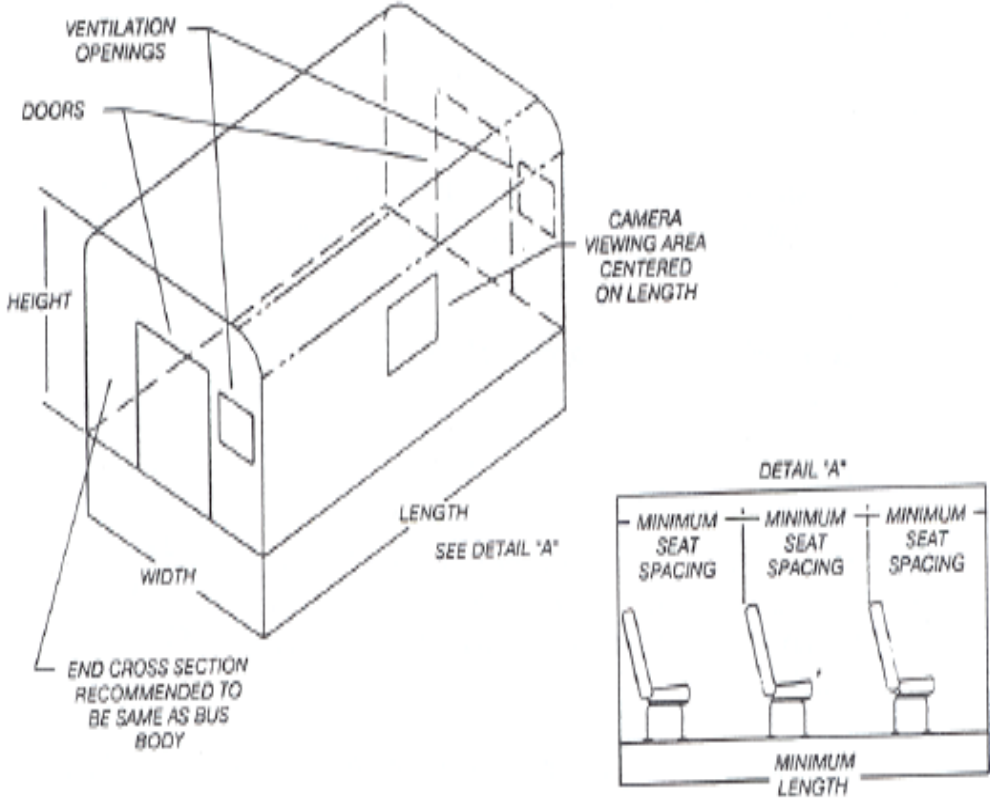

Position A.

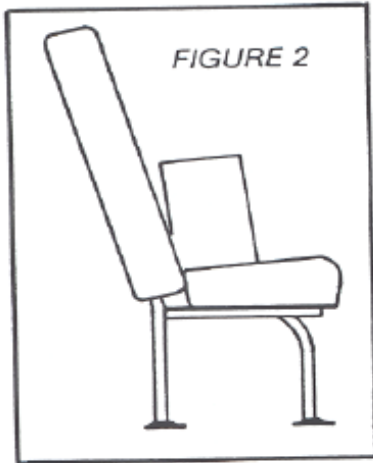

Position ignition source with 18-inch dimension in contact with the seat cushion and touching the seat back. Center the bag on top of the cushion. (See Figure 2.)

Position B.

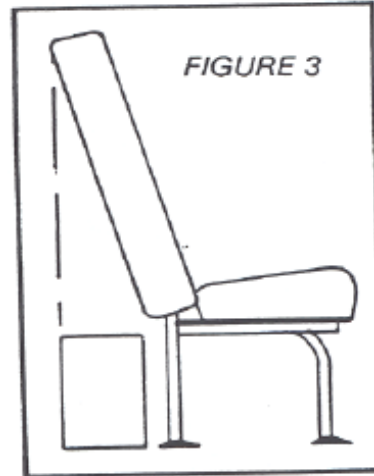

Position the ignition source on the floor behind the seat with 18-inch side resting on the floor and parallel to seat width, centered on width so that the rear of bag does not extend beyond the rear seat back. (See Figure 3.)

214

Position C.

Position the ignition source on the floor on the aisle side of the seat with 18-inch dimension on the floor and perpendicular to the seat width touching the seat leg, with centerline of the bag at the center of the seat back. (See Figure 4.)

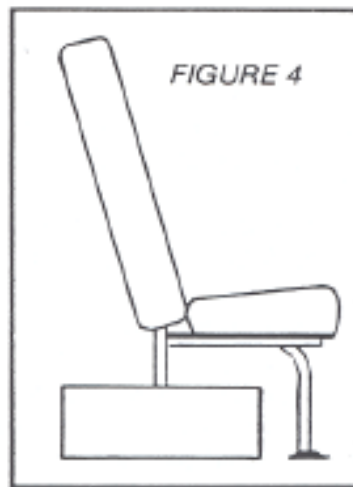

3. A wooden match shall be used to light the ignition source. Time the test, beginning when the ignition source is on fire and ending when all flames are out.
4. After each ignition source position test, weigh seat assembly, including loose material which has fallen off the seat onto the floor.

E. Performance Criteria

For each ignition source position test, the seat tested must meet all of the following criteria. A new seat specimen may be used for each ignition source position test.

1. Maximum time from ignition to flameout shall be 8 minutes.
2. Flame shall not spread to any other seat with the ignition source in Position A and Position C.
3. Weight loss may not exceed 10% of the pretest weight of padding and upholstery.